

TABLE OF CONTENTS**Part II**

2.0	Use
2.1	Introduction
2.1.1	Type code explanation
2.2	Installation
2.2.1	Installation of pump guide system
2.2.2	Preparatory checks
2.2.3	Flushing water connection
2.2.4	Direction of rotation
2.2.5	Lowering the pump into the sump
2.3	Start-up
2.4	Electrical connection
2.4.1	Panel controls
2.4.1.1	Operator safety
2.4.1.2	Minimum requirements
2.4.1.3	Recommended additional controls
2.4.2	Connection tabulation
2.4.3	Level switches
2.4.4	Level control
2.4.5	Required submergence
2.5	Maintenance
2.5.1	Operating troubles
2.6	Maintenance and service
2.6.1	General
2.6.2	Cooling types
2.6.3	Field tests
2.6.3.1	Visual checks after pulling pump unit from sump
2.6.3.2	Motor housing test
2.6.3.3	Oil checking on submersible motors
2.6.3.4	Oil change
2.6.4	Greasing instructions
2.7	Motor cables
2.7.1	Re-connection of cable
2.7.2	Test for leaks
2.8	Overhaul chart
2.9	Assembly / Disassembly
2.9.1	Replacement of mechanical seal
2.9.1.1	Removal of pump side mechanical seal
2.9.1.2	Maintenance of motor side mechanical seal
2.9.1.3	Assembly of back cover
2.9.1.4	Assembly of pump side mechanical seal
2.9.1.5	Leakage test for pump side mechanical seal

Dat: 05.12.05

No: 94-BA 5079E/ 2d

File: Q_TAU_E

2.0 USE

2.1 INTRODUCTION

Each pump unit is equipped with a nameplate attached to the motor, containing all motor and pump data (section 2.1.1). It is **essential** to give the complete data for any inquiry about parts or service.

a) For pumps in normal operation (Fig. 1)

Fig. 1



b) Motors approved for **hazardous location** according norm 94/9/EG (ATEX 100)

- for online operation (Fig. 2).

Fig. 2

- for variable frequency driver (Fig. 3).
These motors are equipped with triple-thermistor according DIN - 44082 - S 150° C

Fig. 3

The HIDROSTAL warranty is void unless the following requirements are met:

1. Temperature protection circuit is wired so as to positively disconnect power to the motor when excessive winding temperature is sensed (Section 2.4.1.2f for wiring instructions).
2. Proper extra-quick-trip overload protectors **M U S T** be used on all three phases of each motor (Section 2.4.1.2e).
3. Optional conductivity probe circuit is wired to a special relay for use with these motors. See Section 2.4.1.3g for wiring instructions and a list of approved relays.

Dat: 05.12.05

No: 94-BA 5079E/ 3f

File: Q_TAU_E

4. Any repairs must be made exactly as per instructions in this manual, and using only genuine HIDROSTAL replacement parts furnished through the HIDROSTAL distribution organisation. Use of any other parts will void the HIDROSTAL warranty.

Prior to shipment, each pump has been tested by the factory for proper mechanical and electrical operation as well as absolute water-tightness of the motor. Disassembly of the pump by other than official HIDROSTAL service centers may cause loss of any remaining warranty.

2.1.1 TYPE CODE EXPLANATION

MOTOR CODE

E N Y P 6 - M N E Q

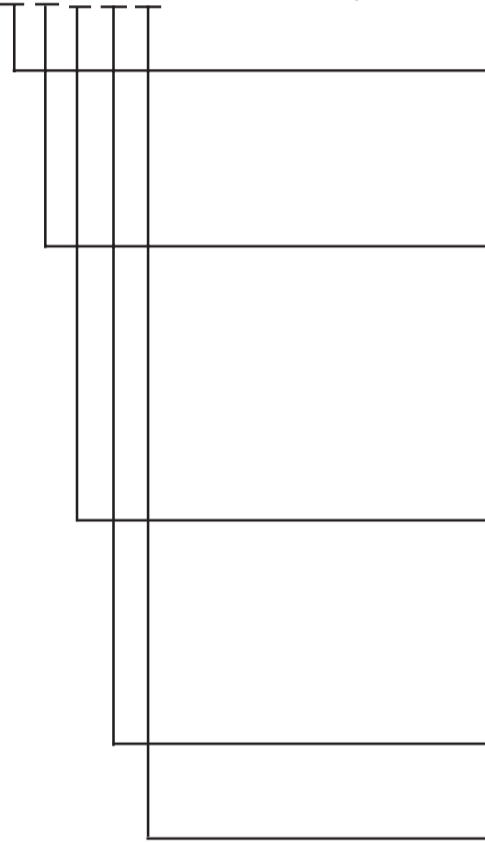

Identification letter of the hydraulic size to which this motor can be assembled.

The sizes are: B, C, D, E, F, H, I, L.

Identification letter of the **cooling type** of this motor.

N = Submersible: cooled by direct transfer of heat from submerged stator housing to surrounding ambient liquid.

Motor size, according IEC-norms:

Line 2001	002	003	004	006	007	014	020	-	030	-	090	130	-	300
Type:	-	B/Z	2/Y	-	3/X	-	4/W	-	5/V	N	6/U	7/T	S	
IEC:	80	90	100	112	132	160	180	200	225	250	280	315	355	

Motor construction classification

Motor speed

- 2 - 2 pole motor
- 3 - two speed, 2/4 poles
- 4 - 4 pole motor
- 5 - two speed, 4/6-poles
- 6 - 6 pole motor
- 7 - two speed, 6/8-poles
- 8 - 8 pole motor
- 9 - two speed, 8/10-poles

Nominal speed	
50 Hz	60 Hz
3000	3600
3000/1500	3600/1800
1500	1800
1500/1000	1800/1200
1000	1200
1000/750	1200/900
750	900
750/600	900/720

Dat: 05.12.05

No: 94-BA 5079E/ 4i

File: Q_TAU_E

MOTOR-CODE, continued:

E N Y P 6 - M N E Q 1

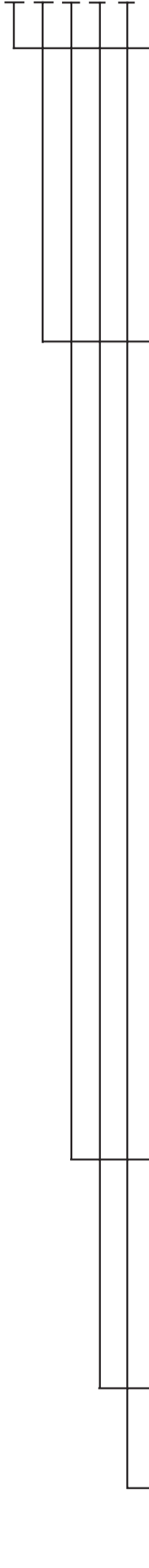

Pump side mechanical seal Pos. 515 type

- C = Fitted with Carbon-ceramic seal faces. Recommended for handling water, activated sludge and non-abrasive liquids.
- G = Silicon carbide seal faces, rubber bellows with external spring.
- M = Tungsten carbide - silicon carbide seal faces, rubber bellows with internal spring. For sludges, slurries and abrasive liquids.
- X = Tungsten carbide - silicon carbide seal faces, stainless steel shell for higher pump pressures and/or higher motor speeds.

Electrical classification:

Standard				Additional elements	Ex-proof						
Motorsize					Motorsize						
W/V	new B/Z	Line 2001	old X/4/5		B	new Z Y X		Line 2001	W/V	old X	
N/U/T	X/Y		6/7**					N/U/T	4/5		
N	N	N	N	without monitoring elements	X	X	X	X	X	X	X
M*	S	S	S	with internal moisture probe	-	I	I	I	I	Y*	-
	F	F	-	with float switch	-	-	Z	Z	Z		
	V	V	F	with internal moisture probe and float switch	-	-	U	U	U		
	-	-	-	with bearing temperature probe	-	-	-	-	-		
W*	W*	-	W	construction with flywheel	-						

* fitted additional elements are mentioned in the order

** Motorsize 6+7: always with SA1-.. (containing all above additional elements)

Voltage of winding (see nameplate):

- A = 230/460 V 60 Hz
- E = 400 V 50 Hz
- G = 415 V 50 Hz
- K = 575 V 60 Hz
- S = special voltage

- Q = Q-hydraulic
- K / L = K-hydraulic

- 1 or blank = Material execution 1
- 5 = Material execution 5
- 6 = Material execution 6

CABLE CODE

N A A 1 - 1 0

- factory code (not important for instruction)
- length in meters

2.2 INSTALLATION

WET PIT PUMPS

All building and technical construction work must be finished before the pump will be installed. Make sure that length of cable supplied is sufficient for local conditions.



Attention: very important: For installation and servicing it is recommended to install a block and tackle or chain hoist over the pump sump (or at least make sure that it could be installed later on). The lifting capacity of the crane has to support at least double the weight of the pump. There should be a water supply of about 4 bar (70 psi) pressure to wash down the pump when removed from the sump.



Before installing any accessories or the pump ensure that the atmosphere is not potentially explosive.



During the installation of the pump make sure that the free ends of the cables **NEVER CONTACT WATER.**



2.2.1 INSTALLATION OF PUMP GUIDE SYSTEM (Fig. 4)

- Fasten the upper guiderail bracket. Be sure to leave enough space for sliding shoe.
- Sump floor where the discharge stand is to be placed must be even and level. Fasten the discharge stand to the sump floor with cast-in-place or expansion-type bolts and nuts so that the guide rail pins or recesses on the discharge stand are vertically in line with (i.e. directly below) the guide rail pins on the bracket.
- The guide rails should be made from galvanized standard (or stainless steel) pipe. Cut pipe to the correct length. Put lower pipe ends in discharge stand guiderail pins or recesses. Unbolt upper guide rail bracket. Insert pins into upper pipe ends and re-bolt it. Check to see that the guide rails are exactly vertical and parallel.
- The discharge pipe must be connected without stress or misalignment to the discharge stand.

If a check valve is installed close to the pump, air must be vented from the pump casing or discharge piping (before the check valve) during first start-up to ensure priming (Section 2.2.3, Fig. 5).

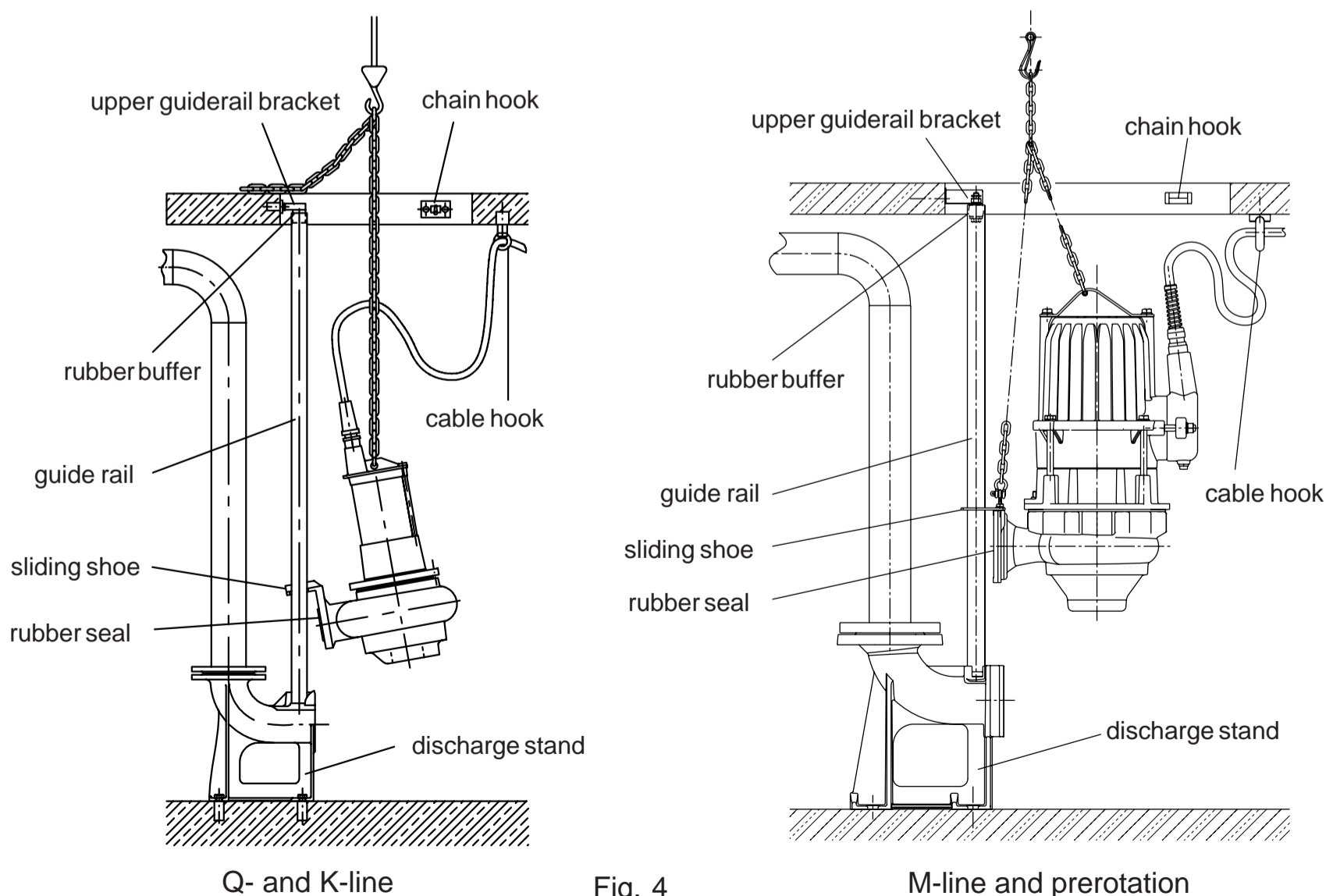

Fig. 4

**2.2.2 PREPARATORY CHECKS**

Before lowering the pump into the sump check to see that:

- The **lifting chain** or **steel lifting cable** is **correctly fastened** to the lifting eyes.
- The **cable entry assemblies** on motor have **not been damaged** or loosened and that the cables are firmly gripped by the cable entry assemblies.
- The **cables** have **not been damaged** during transportation or installation. Look especially for nicks and cuts on insulation; any damage penetrating through the outer layer of the cable will require replacement of them.
- The **cables** are **long enough** and that they can follow the pump unhindered.
- The **cable ends** have **never** come **in contact with water**.
- The rubber seal on the pump discharge is correctly seated in its groove, and is not damaged.
- The rubber seal is thoroughly greased.
- The **direction of rotation** is **correct** (Section 2.2.4, Fig. 6).

2.2.3 FLUSHING WATER CONNECTION

Pumps are supplied with a flushing water connection (service connection "F", Fig. 5).

For normal sewage application this connection is not used. However, in special cases when pumping high concentrations of sludge or mud, it should be connected. It will conduct cleaning water between impeller and pump side mechanical seal (515), providing periodic removal of accumulated solids.

Flushing water must be pressure-regulated between 0,5 to 1 bar (7 to 14 psi) above pump discharge pressure. Water is controlled by a solenoid valve on a time clock. Adequate duration of each flushing is 60 seconds; frequently of flushing must be established for each different installation.

The quantity of flushing water varies according to pumps size and application: in most cases, flow rates of 6-8 litres per minute will be sufficient.

Connection "F" may be used to manually bleed the air from the casing prior to start-up (Section 2.2.1d), if there is no other place for air to escape through the discharge piping.

2.2.4 DIRECTION OF ROTATION

Before lowering the pump into the sump, make electrical connections as indicated in Section 2.4.2 and check the direction of rotation. This must be counter-clockwise viewed from suction end. Check impeller rotation by suspending pump from the lifting eyes, resting inclined on the floor, and start up for one second. The starting jerk should be counter-clockwise viewed from driving side (Fig. 6).

This procedure must be repeated for each speed, if units are multi-speed pumps.

**WARNING:**

If rotation is not correct on multi-speed or multi-pump installations, **only change the pump cable leads of the pump or speed with wrong rotation at its starter in the control panel. DO NOT** change the primary power leads coming into the control panel: This would change the rotation of all pumps or speeds.

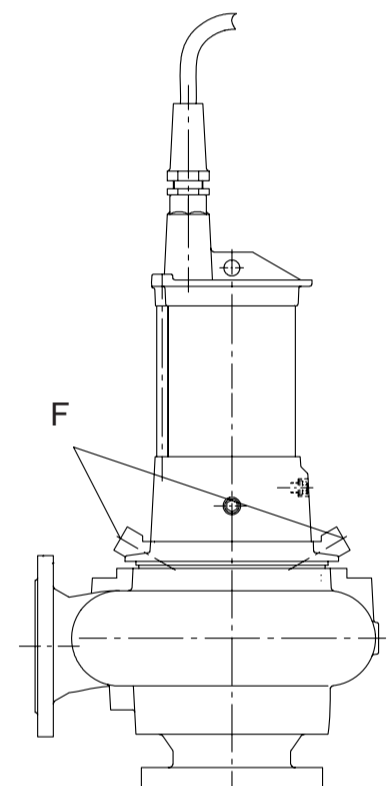

Fig. 5

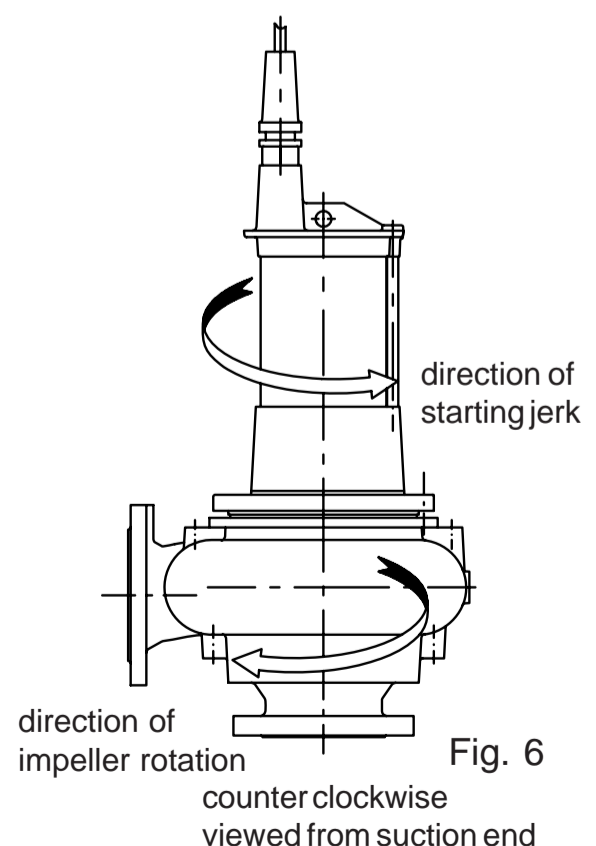

Fig. 6

Dat: 05.12.05

No: 94-BA 5079E/ 7e

File: Q_TAU_E



2.2.5 LOWERING THE PUMP INTO THE SUMP

- **Clear the sump bottom** carefully of all **building debris** and other solid particles.
- **Lubricate the rubber seal** with grease.
- Lift and move the pump to a position directly over the guides until the sliding shoe fits correctly. Lower the pump steadily down to seat against the discharge stand. The sealing of mating faces is accomplished by the rubber seal that is incorporated in the sliding shoe attached to the pump discharge flange. This is pressed to the discharge stand (after the pump is in position) by the pump's own weight.
- When the chain is slack, unfasten the chain from the lifting device and fasten it to its retaining hook, so that there is as little slack as possible.



WARNING:



The **chain and cable** must be fastened **reliably** to their retaining hooks. **If they come loose they may be drawn into the pump suction** with severe **destructive consequences**.



2.3 START-UP

Prior to starting, check that:

- level controls are correctly set
- off-level is sufficiently high to prevent air entrance to the pump suction
- suction and discharge gate valves are completely open
- flood pump sump
- the pump may not be started if potentially explosive atmosphere is present



STARTING OF PUMP

Never start pump against closed valves (except non-return valves).

Start the pump using manual operation. **Measure the amperage** drawn on each phase leg. Record and **verify** these **readings** with the **nameplate ratings**. If amperage is more than 5 % higher, stop pump and check probable causes according to "Operating Troubles" chart (Section 2.5.1).

Once preliminary checks are complete, place the pump into automatic operation. Cycle the system through several wetwell pumpdowns to observe that level controls are properly set and functioning correctly. **Observe** that the **alarm system** and change over switch (if included in control panel) **are working properly**.

Log date and hours meter reading, and set pump for automatic operation. Perform maintenance according to Section 2.6.

GENERAL OPERATING CONDITIONS

The pump should not be allowed to operate continuous-duty outside of performance curve: high discharge pressure with low flow or low discharge pressure with high flow. Bearing life is shortened and abrasive wear is accelerated in these operating conditions.

OPERATING TROUBLES

See chart, Section 2.5, maintenance.



2.4 ELECTRICAL CONNECTION

The electrical connection must be made by specialists in accordance with local specifications.



The explosion proof class of the pump is   II 2G EEx d IIB T4 (T3).

Switch boxes and pump control devices may not be mounted in potentially explosive atmosphere. Ensure that the protection equipment is correctly connected.

The motor winding leads will be factory-connected according specifications (see nameplate).

Make sure that the power supply to the control panel is the same as on the pump nameplates (tolerance +/- 5 %). From 5 % to 10 % lower voltage, there may be a slight diminishing of hydraulic performance and a slight increase in amperage, but no harm to the motor. For voltages lower than 10 % of rating, severe performance drop and excessive draw (motor overheating and considerable operating problems) can be expected. The motor ratings shown on the nameplate are for ambient temperature (liquid and air) of up to 40° C. For higher temperatures, contact factory.

All electrical connections are made according to electrical diagram.

Dat: 05.12.05

No: 94-BA 5079E/ 8d

File: Q_TAU_E

 **2.4.1 PANEL CONTROLS** **2.4.1.1 OPERATOR SAFETY**

Prior to any work on the pump, the power supply must be disconnected either by means of a locked isolator or by removing the fuses from the panel. It is not safe enough to switch off the control switch. A wiring mistake or a control system malfunction could put the motor back into operation.

2.4.1.2 MINIMUM REQUIREMENTS

The control panel must contain the following components:

- a) **Isolation switch**, preferably lockable.
- b) **Slow trip fuses or circuit breakers** in each incoming phase.
- c) **Lightning protection**. Lightning arrestor on each incoming phase, if there is any possibility of lightning damage.
- d) **Motor starter**. Full-voltage magnetic-contact starter has to be sized according to local electrical code requirements based on motor power rating.
- e) **Extra quick trip overload protectors**. They must be selected according to the amperage indicated on the nameplate. They must trip within 6 seconds on locked rotor condition (approximately 6 times full load amps) in order to adequately protect the motor windings; consult "trip curve" of overload protectors to ensure they meet this requirement.

**WARNING:**

Warranty on submersible pump motor is void unless proper extra quick trip overload protectors are used on all motor phases. Claims for warranty repair of motors must include documentation that proper overload protectors have been installed.

- f) **Temperature sensor circuit**. Each motor is manufactured with **temperature limit switches** in the winding-head (control leads 1 and 2). They are Bimetal type switches (similar to "Klixon"). They can be connected directly into the motor control circuit, as long as this circuit does not exceed 220/240 volts, 2,5 amps.



Explosion-proof submersible motors have in addition to the temperature limit switch a **temperature regulator** (control leads 1 and 3). This will disconnect 12 to 15° C before the temperature limit switches will disconnect.

For variable frequency driver (Section 2.1) the motors must be equipped with triple-thermistor according DIN 44082-S 150° C. For Ex-proof motors this is prescribed and may only be used with thermistor control units.

As alternative (special order) thermistors can also be used for normal motors. All motors equipped with thermistor have a label at the end of the cable with the following words:

**ATTENTION! Semiconductor switch! More than 2.5 Volt destroys the motor winding!**

Warranty is void if these leads are not connected to immediately de-energize the motor when their circuit is opened due to internal motor malfunction or temporary overheating.

g) Connections of the motor

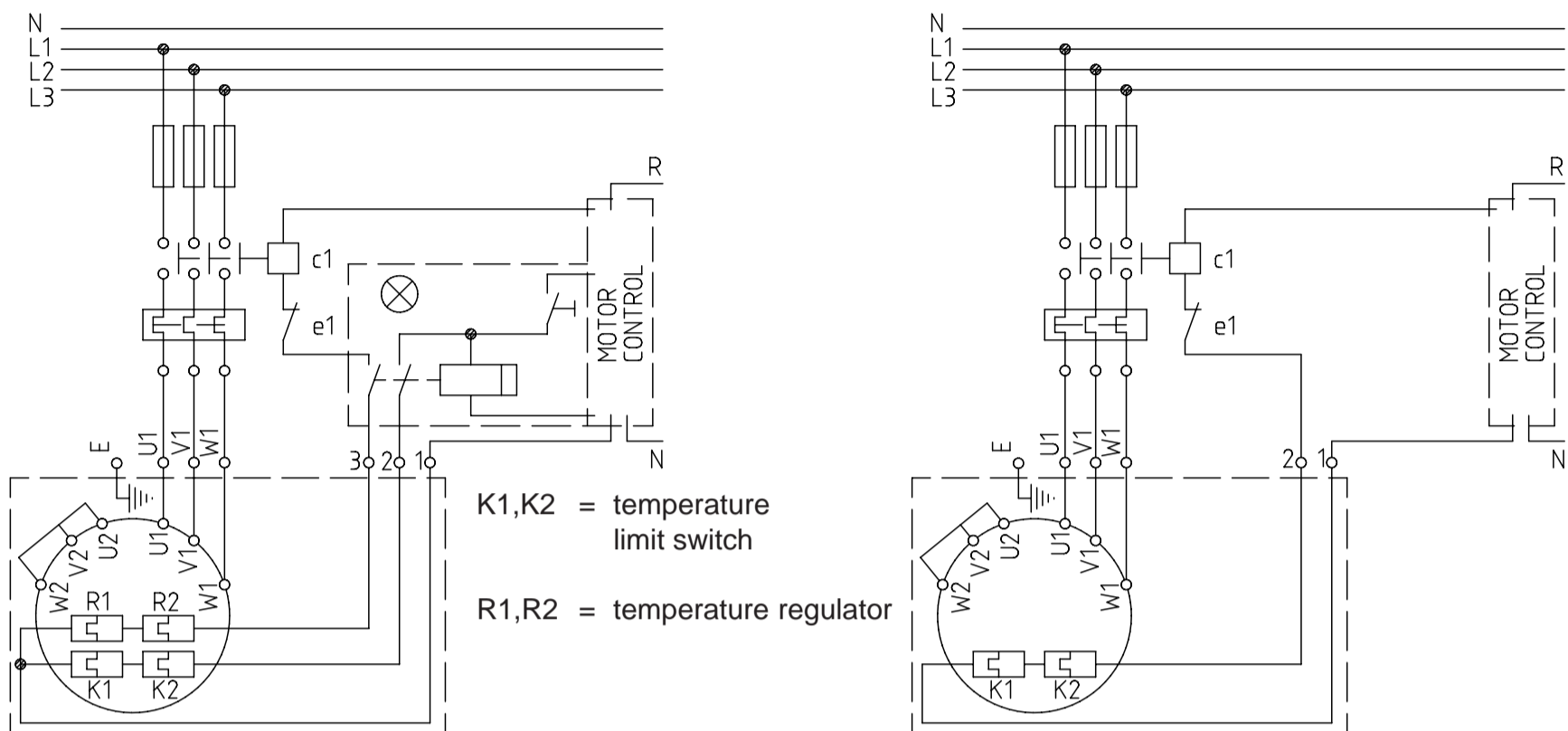

EEx-proof execution

The control leads 1 and 3 (**temperature regulator**) can be connected in such a way that the motor can automatically re-start after the motor cools down and the circuit is re-closed. A motor overheated due to emergence from its cooling water can resume operation as soon as he is submerged.

The control leads 1 and 2 (**temperature limit switch**) have to be connected in such a way that the motor cannot automatically restart. The reason for the failure of the temperature controller circuit to disconnect first must be determined and corrected before the motor is put back into service.



WARNING:

Note that the temperature sensors will only de-energize the motor when gradually overheated due to electrical malfunction. These devices are not a protection for quick temperature rise due to overload such as a locked rotor condition. They are **not** a sufficient substitute for the overload protectors specified in (e) above.

Standard execution

The control leads 1 and 2 can be connected in such a way that the pump can automatically re-start after the motor cools down and the circuit is re-closed. A motor overheated due to emergence from its cooling water can resume operation as soon as he is submerged.

2.4.1.3 RECOMMENDED ADDITIONAL CONTROLS

- a) **"Hand - Off - Automatic" switch.**
- b) **Low voltage terminals for level switches.**
- c) **Pump-on and pump-failure lamps.**
- d) **Hours run meter:** Important to schedule service.
- e) **Change-over switch** for multiple-pump stations.
- f) **Alarm-system for high sump-level:** Preferably on a separate power supply, to ensure continued protection in the event of a main power supply failure.
- g) **Moisture probe**
- h) **Float switch**
- i) **Bearing temperature probe**

Dat: 05.12.05

No: 94-BA 5079E/10f

File: Q_TAU_E

2.4.2 CONNECTION TABULATION

Each cable set provides three or six power leads per speed, one earth lead and additional leads for temperature protection and seal failure circuits.



To connect the motor to the power supply it is not necessary to open it. This should be avoided in order to retain the original factory-hermetic seal.

If the sealing of the motor cover is disturbed, tightness tests must be performed as per Section 2.7.

Power leads of the motor are marked according to the following table:

MOTOR-TYPE	number of speeds	number of conductors (a)	speed (b)	winding connection (c)	markings on cable end, according DIN VDE 0530 norms
up to 4 kW, direct start	1	3+C+E		Y	U1 V1 W1
over 4 kW star/delta start	1	6+C+E		Δ	U1 V1 W1 W2 U2 V2
two speed by Dahlander system Y/YY, direct start	2	6+C+E	N H	Y YY	1U 1V 1W 2U 2V 2W
pole change, each speed direct start	2	6+C+E	N H	Y Y	1U1 1V1 1W1 2U1 2V1 2W1
pole change, low speed: direct start, high speed: star/delta start	2	9+C+E	N H	Y 1) Δ	1U1 1V1 1W1 2U1 2V1 2W1 2U2 2V2 2W2
pole change, low and high speed with star/delta start	2	12+C+E	N H	Δ Δ	1U1 1V1 1W1 1U2 1V2 1W2 2U1 2V1 2W1 2U2 2V2 2W2

a) E = earth (yellow-green)
C = control leads



for EEx (explosion proof) motors,
with two-level temperature
protection circuits: *
lowest, temperature regulator 1 to 3
highest, temperature limit switch 1 to 2
seal failure circuit (optional) see note

for normal motors: *
temperature protection circuit 1 to 2
seal failure circuit (optional) E to 4



NOTE:

On EEx, seal failure circuit will always be in a separate cable originating near bottom of motor.
* If in doubt whether motor is normal or Ex-proof refer to Section 2.1.1.

b) N = low speed H = high speed

c) Y/YY = direct start (Dahlander) Δ = start possible by star/delta
1) = the starting current at this speed is lower than the starting current at high speed by star/delta.

**2.4.3 LEVEL SWITCHES**

- Remark: Observe the relevant instructions for level controls in explosion proof installations.
- It is recommended to use an intrinsically safe circuit for the level controls, for explosion-proof installations.
- For the on and off levels, use control systems that are appropriate for the pumped liquid.
- Use a floating-ball type switch for the high-level alarm, even when there is another type used for the pump control (this has proven to be the most fail-safe type).
- The floating ball for the alarm should be placed at a reasonable distance above the highest pump start level to avoid false alarms.

2.4.4 LEVEL CONTROL

"ON" and "OFF" levels must be set in such a way as to provide sufficient sump capacity between "ON" and "OFF" so that the pump cannot be switched on more than 10 times per hour. Higher starting frequency may damage the motor control devices in the panel and will cause excessive power consumption. The following formula will calculate the required minimum sump capacity:

$$V = \frac{0.9 \times Q_p}{Z}$$

V = sump capacity or volume, between on and off levels (in cubic meters)
Q_p = pump flow for one pump (in litres per second)
Z = number of starts per hour (Z = 10, maximum)

2.4.5 REQUIRED SUBMERGENCE

Hidrostal submersible motors are rated to operate continuously at maximum output kW, when **fully** submerged in liquid of 40° C or less. If pump design require the motor to operate without full submergence for long periods of time, use a Hidrostal "IMMERSIBLE" motor, with self-contained cooling. However, with a Hidrostal "SUBMERSIBLE" motor, it is permissible to place the shut off level **below** the top of the motor, to reduce sump depth and associated construction costs, if the following points are considered:

- 1) The exact time that a submersible pump will run without being submerged in cooling liquid, before the temperature control circuit trips out, is very difficult to predict (factors: ambient air and liquid temperature, hydraulically load of the motor, operating point on the pump-curve). The following times are maximum run times for a fully-loaded motor previously running fully submerged in 15° C liquid, and suddenly running in 40° C air:

Motor size B,Y,002,003:	5 minutes dry run time
Motor size Z,X,004,006,007:	7 minutes dry run time
Motor size 4/W,5/V,6/U,7/T,014,020,030,090,130:	9 minutes dry run time

The sump should be designed to ensure the pumps will not run dry longer than above, under normal conditions.

- 2) If the motor **does** run in air for a longer time (for example where sump inflow **exactly** matches pump discharge), he will be shut-off by its temperature control circuit with no harm to the motor. Ensure that there is sufficient sump volume to contain the incoming liquid during the time that the motor takes to cool down enough to re-start. Approximate cooling down times for various size motors are as follows (maximum liquid temperature of 15° C):

Motor size B,Y,002,003:	3 minutes to re-start
Motor size Z,X,004,006,007:	4 minutes to re-start
Motor size 4/W,014,020:	5 minutes to re-start
Motor size 5/V,030:	8 minutes to re-start
Motor size 6/U,090,130:	11 minutes to re-start
Motor size 7/T:	15 minutes to re-start



Care should be taken to avoid the production of vorticies and entrainment of air.

Dat: 05.12.05

No: 94-BA 5079E/ 12e

File: Q_TAU_E

2.5 MAINTENANCE

2.5.1 OPERATING TROUBLES



Instructions for pumps in potentially explosive atmosphere must be observed.



Ensure, that no work is carried out in a potentially explosive atmosphere.

POSSIBLE REASONS	TROUBLE						
	No flow	Flow not sufficient	Head not sufficient	Reduction of flow or head after start up	Vibrations	Motor overload	Motor does not start
1. Pump not sufficient submerged, not vented	X						
2. RPM too low	X		X				
3. RPM too high					X	X	
4. Air entrance into suction line	X	X		X	X		
5. Discharge line clogged / Valve closed	X				X	X	
6. Air or gas in pumped liquid	X	X	X	X	X		
7. TDH too high (higher than calculated)	X	X			X		
8. Suction head too high				X	X		
9. Insufficient suction head on hot liquids		X			X		
10. Insufficient submergence of suction	X	X	X	X	X		
11. Sludge concentration higher than assumed		X	X			X	
12. Specific weight of medium higher than assumed						X	
13. Impeller or suction line clogged	X	X			X		
14. Wrong direction of rotation	X	X	X				
15. Impeller clearances too high		X	X				
16. Damaged impeller		X	X		X		
17. Thermal overloads tripped; control switch off							X
18. Motor damage					X	X	X
19. Low voltage		X	X			X	X
20. Attachments loose					X		
21. Bearings worn out					X		
22. Impeller out of balance					X		
23. On-level switch not overflowed, or damaged							X
24. Impeller too small			X				
25. Impeller dragging against suction cover					X	X	
26. Thick sludge and tight impeller clearance						X	
27. Air or gas on impeller backside	X		X				

! 2.6 MAINTENANCE AND SERVICE**2.6.1 GENERAL**

Ex Pay attention to the relevant instructions.

⚡ Before doing any work on the pump unit, switch off main isolator switch and remove fuses from panel.

The following checks (Section 2.6.3) can be done in the field. When a repair is indicated, send the pump unit to the nearest authorized Hidrostat service station.

! WARNING:
⚡ When disconnecting the power cable at the control panel, take care that the cable ends **CANNOT** come in contact with water. Replace the plastic cable-end shipped with the pump (if this is no longer available, wrap the cable ends inside a plastic bag, and seal with tape) for water-tightness during handling and shipping.

2.6.2 COOLING TYPES

HIDROSTAT submersible motors must be operated submerged in the liquid for continuous duty (cooling type: second digit of motor code).

SUBMERSIBLE COOLING - Code "N"

This type transfers motor heat directly through the stator housing to the surrounding ambient liquid.

KEY FOR SYMBOLS ON FIG. 7:

MOT = Motor room opening
OIL = Oil drain opening
F = Flushing connection
(see Section 2.2.3)

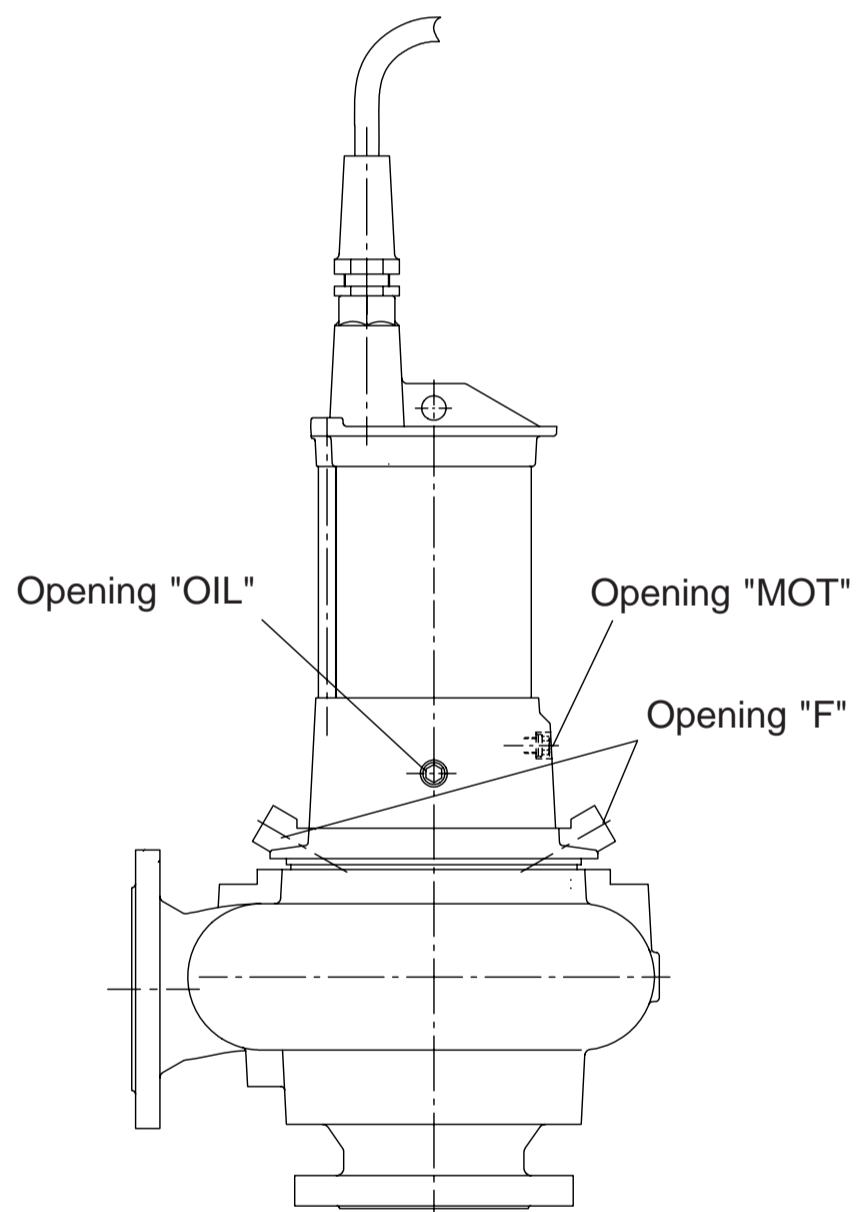

Fig. 7

2.6.3 FIELD TESTS**2.6.3.1 VISUAL CHECKS AFTER PULLING PUMP UNIT FROM SUMP**

- Check pump and motor for possible mechanical damage. Pay attention to the cable.
- If pump volume or pressure are not acceptable, check impeller clearance (see manual for hydraulic).
- Check overload relay, fuses and time relays (if any) for correct setting.
- Check correct function of level control.
- Check insulation resistance of motor windings and cables with a high-voltage ohm-meter ("megger"). This initial test should be made from the point where the cables attach to the motor starter. Check from each winding lead to the other two winding leads and to the ground lead.

Dat: 05.12.05

No: 94-BA 5079E/14e

File: Q_TAU_E

INSULATION CHART		
CONDITION OF MOTOR AND CABLES	OHM VALUE	MEGAOHM VALUE
A new motor.	2'000'000 (or more)	2
A used motor which can be re-installed in the well.	1'000'000 (or more)	1
MOTOR IN PIT. Ohm readings are for cable plus motor. A motor in the pit in reasonable good condition.	500'000 - 1'000'000	0.5 - 1.0
A motor which may have been damaged by lightning or with damaged leads. Do not pull the pump for this reason.	20'000 - 500'000	0.02 - 0.5
A motor which has wet or damaged cable or windings. The pump should be pulled soon and repairs made to the cable or the motor dried and replaced. The motor will not fail for this reason, but it will probably not operate for long.	10'000 - 20'000	0.01 - 0.02
A motor which has failed or with completely destroyed cable insulation. The pump must be pulled and repaired or the motor replaced. - The motor will probably not operate for long. - The motor will not run in this condition.	Less than 10'000 0	0 - 0.01 0



WARNING:

Do **NOT** "Megger test" control leads when thermistors are fitted: Voltages over 2,5 V will cause thermistors to fail, and may destroy the winding.

Any reading less than 1.0 Megaohm could indicate failure of cable or winding insulation. If failure is indicated, remove pump with cable and proceed to Section 2.7 for further tests.

2.6.3.2 MOTOR HOUSING TEST

This test consists of a check on the condition of the motor side mechanical seal and/or motor housing "O"-rings.

Stand pump vertically on its suction flange. Remove screw plug "MOT" (Fig. 7) with copper washer (536) so that any liquid can run out. Do the following repairs according to what comes out of the motor housings:

WATER	}	General overhaul with change of bearings and seals
MIXTURE WATER/OIL		
OIL	=	Change motor side mechanical seal (Pos. 516)
NO LIQUID (DRY)	=	Stator housing is OK. No defect.



WARNING:

This screw plug must be completely watertight. Sealing surfaces must be clean and smooth before assembly. Heat new copper ring to dull red and immediately quench in water to soften copper ring for best seal. All copper rings supplied by Hidrostal are softened.

2.6.3.3 OIL CHECKING ON SUBMERSIBLE MOTORS

This is a check on the condition of the pump side mechanical seal. For pump units supplied with a moisture probe, total failure of the pump side seal will be indicated by activation of the resistance relay. However, even without this circuit, a slow failure can be detected earlier by the following oil check.

Oil checking must be done after the first 1'000 hours of operation and once a year thereafter.

Immediately before checking, run the pump for a few minutes to distribute any impurities throughout the oil. Raise the pump out of the sump and clean it with a water hose.

Oil level check

Stand pump with shaft vertical, and remove screw plug marked "OIL". Coolant level must be at the level of opening "OIL".

If coolant is far below this level, the pump side mechanical seal may have leaked and may require replacement (Section 2.9.1). If oil level is only a small amount below this level, proceed with following test. Top-up with new oil and re-check in 200-500 hours (Fig. 8).

Oil quality check

Lay pump down horizontally with opening "OIL" (536) upwards. Remove screw plug "OIL". Insert a tube or rubber hose, place a finger over top of tube and remove it with a small sample. Repeat until a sufficient quantity has been collected for observation. Evaluation will show one of three conditions:

- a) If oil is clear there are no problems with the pump side seal. Fill oil back in again with pump vertical to the level of opening "OIL" and close with screw plug and a new softened copper seal ring.
- b) If there is just a little water in the oil but the oil is clear, repair of the pump is not necessary. Remove oil and separate water from oil (Section 2.6.3.4).

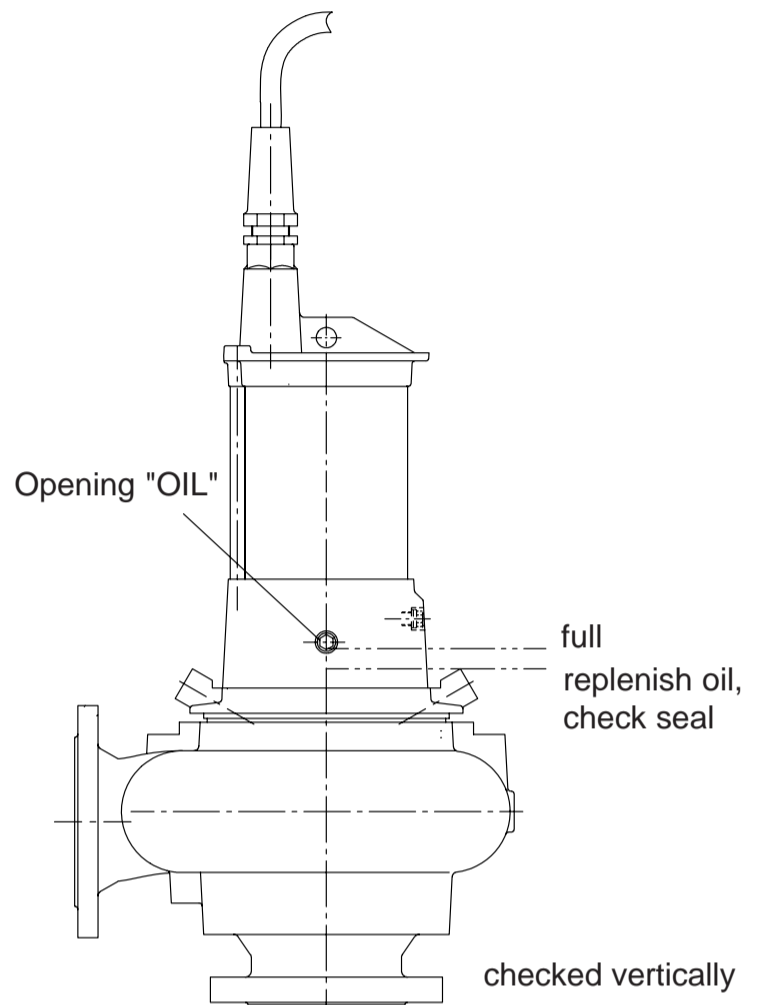

Fig. 8

Pour back the clean oil into the mechanical seal housing and close opening "OIL" with screw plug and softened copper seal ring (536). However, check oil quality again after 500 hours of operation.

With a new mechanical seal (515) it is possible that during the run-in period a small amount of water could enter into the oil chamber. Thus, if at the first check after start-up a small quantity of water is detected, it can be neglected.

Oil with a small amount of water will be milky in appearance, but will still be of very low viscosity, that is, it will still run much more freely than motor oil, almost as thin as kerosene.

- c) If too much water has entered the oil, the viscosity will be much higher, then oil will be as thick as motor oil or even thicker. In this case, or when sludge or sewage smell are detected in the oil, the pump side mechanical seal (515) must be repaired or replaced.

Replace oil with new oil only if strongly contaminated, otherwise separate water from oil and re-use oil. Required oil must be extremely low viscosity. Factory uses the following oil:

Specific gravity at 20° C	0,812	g/ml
Viscosity at 40° C	3,5	mm ² /s (cst)
Solidification point	-38,0	° C
Flash point	132,0	° C
Burning point	142,0	° C
Evaporation energy	251,0	kJ/kg
Solubility in water	none	

Other recommended oils:

Shell Morlina 5 or others with equal specification. The specified low viscosity is very important for proper cooling.



If another oil is used the consistency with the used elastomers must be checked.

2.6.3.4 OIL CHANGE

Remove screw plug "OIL" (536) and drain oil chamber casing (504) completely, by turning the pump around slowly until opening "OIL" is upside down (Fig. 9). On larger motor sizes there may be another screw plug directly below the opening "OIL" on the back cover (507). Removing this plug will help remove the last bit of oil.

When the oil chamber casing is completely empty stand pump vertically on suction flange and refill with separated oil or new oil. The correct level is reached when the oil is at the bottom of opening "OIL".

Re-install screw plug "OIL" with softened copper seal ring.

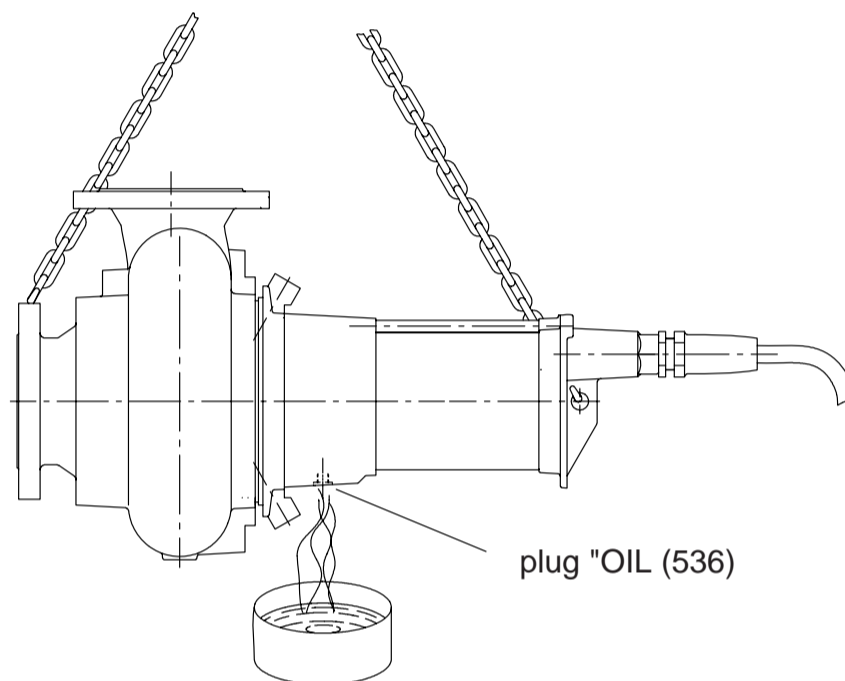

Fig. 9

2.6.4 GREASING INSTRUCTIONS

Hidrostal motors use bearings which are grease lubricated. For re-lubrication, grease is handpacked into the bearings when the motor is disassembled during a major overhaul. Sufficient grease is provided initially and at each overhaul to allow for the number of operating hours between overhauls ("Overhaul Chart", Section 2.8). The overhaul should be done by an authorized Hidrostal service center.



CAUTION:

The overhaul of Ex-proof-motors must be done in the factory or in an authorized Hidrostal service center, otherwise the Ex-certification will be invalidated.

No other lubrication service is required between overhauls for these motors.

For regreasing we recommend:

STABURAGS NBU 8 EP by Kluber-Lubrication.

This grease is of a mineral oil base containing a barium complex as thickener.

Typical characteristics:

Colour	beige	
Apparent dynamic visco. (approx.)	6000	mPas
Operating temperature range	-30..150	° C
Max. temperature (short time)	170	° C
Consistency class (NLGI)	2	
Penetration DIN ISO 2137 (0.1 mm)	280	
Dropping point DIN ISO 2176	> 220	° C
Corrosion protection DIN 51802	0	
RPM-parameter (n x d m)	5 x 10 ⁵	

**2.7 MOTOR CABLES**

Whenever opening motor housing, it is imperative that all O-rings have to be replaced with new items supplied from HIDROSTAL. O-rings glued-up from bulk stock are totally unsatisfactory for this critical application; the glued joint will inevitably leak water into the motor after a short time.

If tests conducted through the cables in the field (Section 2.6.3.1) showed insufficient insulation resistance, and if humidity relay has not tripped (continuity exists between lead 1 and 2), it can be assumed that the insulation failure is in the cable rather than in the stator. Remove fasteners (509) and carefully lift off cable cover.

Cut the leads between cable and winding and now make a separate "megger" test on cable and winding. If windings are at fault, send the entire motor to the nearest authorized Hidrostal service station. If cable is at fault, a new cable set can be installed.

2.7.1 RE-CONNECTION OF CABLE

Place O-ring (525) into position around the seal face on cover (500). Cables should be re-connected to the winding leads, using new insulated splices. Take care that this insulation is rated for 110° C.

2.7.2 TEST FOR LEAKS

Before putting the pump back into operation after opening of the motor (as when changing cables), a test for leaks should be carried out as follows:

Connect source of dry air (from air compressor or bicycle hand pump) to opening left by removal of screw plug "MOT" (Fig. 7). Air pressure should be a maximum of 0.5 bar (7 psi). Motor should then be totally submerged in a test tank.



WARNING:
Do not immerse loose end of cables.

If any continuously escaping bubbles are detected, motor cover is not water-tight. The preceding procedure for cable installation should be repeated to eliminate leaks.

Dat: 21.04.10

No: 94-BA 5079E/ 18i

File: Q_TAU_E

2.8 OVERHAUL CHART



WARNING:



The overhaul of Ex-motors must be done in factory or in a authorized Hidrostat service center, otherwise the Ex-certification will be invalidated.

Motor type	motor-side seal	pump-side seal	seal oil lit.	hours between regreasing
BNBA2	25 mm	20 mm	1.0	20'000
BNZK2	25 mm	20 mm	1.0	20'000
BNZR2	25 mm	20 mm	1.0	20'000
BNZY2	25 mm	20 mm	1.0	30'000
CNBA2	25 mm	20 mm	1.0	30'000
CNZR2	25 mm	20 mm	1.1	20'000
CNZY2	25 mm	20 mm	1.1	20'000
CNYS2	1 1/2"	1 1/8"	1.5	20'000
CNYT2	1 1/2"	1 1/8"	1.5	30'000
DNYS2	1 1/2"	1 1/8"	1.2	20'000
DNYT2	1 1/2"	1 1/8"	1.2	20'000
DNXA2	1 1/2"	1 1/8"	3.6	25'000
DNXB2	1 1/2"	1 1/8"	3.6	25'000
DNXK2 / DNXL2	1 1/2"	1 1/8"	3.6	25'000
DNXT2	2"	1 1/2"	4.0	25'000
DNXQ2 / DNQ3	2"	1 1/2"	4.0	25'000
DNXZ2	2"	1 1/2"	4.0	25'000
DNXW2	2"	1 1/2"	4.0	25'000
DNWS2	2 1/2"	1 1/2"	9.0	25'000
ENWS2	2 1/2"	2"	9.0	25'000
EN5S2	3"	2"	18.0	20'000
ENVT2	3"	2"	13.0	20'000
BNBA4	25 mm	20 mm	1.0	30'000
BNZK4 / BNZR4	25 mm	20 mm	1.0	30'000
CNBA4	25 mm	20 mm	1.0	30'000
CNZK4 / CNZR4	25 mm	20 mm	1.1	30'000
CNZY4	25 mm	20 mm	1.1	30'000
DNBA4	25 mm	20 mm	0.9	30'000
DNYK4	1 1/2"	1 1/8"	1.2	30'000
DNYS4	1 1/2"	1 1/8"	1.2	30'000
DNYT4	1 1/2"	1 1/8"	1.2	35'000
DNXA4	1 1/2"	1 1/8"	3.7	35'000
ENYT4	1 1/2"	1 1/8"	1.2	35'000
ENXA4 / ENXB4	1 1/2"	1 1/2"	3.8	45'000
ENXK4 / ENXO4	1 1/2"	1 1/2"	3.8	45'000
ENXR4 / ENXR5	1 1/2"	1 1/2"	3.8	45'000
ENXW4	2"	1 1/2"	4.7	45'000
ENXY4 / ENXY5	1 1/2"	1 1/2"	3.8	40'000
ENXZ4	2"	2"	4.7	40'000
ENWB4	2 1/2"	2"	10.0	40'000
FNXT4	2"	2"	6.0	40'000
FNXW4 / FNZ4	2"	2"	6.0	40'000
FN4B4 / FN4C4	2 1/2"	2"	12.0	40'000
FN4S4 / FN4T4	2 1/2"	2"	12.0	40'000
FNWB4 / FNWS4	2 1/2"	2"	12.0	40'000
FNWT4	2 1/2"	2"	12.0	40'000
FN5B4	3"	2"	20.0	35'000
FNVB4	3"	2"	17.0	35'000
FN5V4	3"	3"	20.0	30'000
HN5C4 / HN5T4	3"	3"	22.0	35'000
HNVC4 / HNVT4	3"	3"	19.0	35'000
HNNT4	3"	3"	19.0	35'000

Motor type	motor-side seal	pump-side seal	seal oil lit.	hours between regreasing
HN6S4 / HN6SU	95 mm	3"	26.0	20'000
HNUC4 / HNU4	95 mm	3"	24.0	20'000
IN6S4	95 mm	3"	45.0	20'000
INUT4	95 mm	3"	43.0	20'000
IN7T4	100 mm	100 mm	47.0	18'000
INTT4 / INTZ4	100 mm	100 mm	47.0	18'000
DNYK6 / DNYS6	1 1/2"	1 1/8"	1.2	35'000
ENYS6 / ENYT6	1 1/2"	1 1/8"	1.2	35'000
ENXA6 / ENXR7	1 1/2"	1 1/2"	3.8	50'000
FNXT6 / FNXT7	2"	2"	6.0	50'000
FNXZ6 / FNZ7	2"	2"	6.0	50'000
FN4A6	2"	2"	9.0	50'000
FNWA6 / FNWB6	2 1/2"	2"	12.0	50'000
HN4B6 / HN4S6	2 1/2"	2"	14.0	50'000
HNWB6 / HNWS6	2 1/2"	2"	14.0	50'000
HN5B6	3"	3"	22.0	45'000
HNVB6	3"	3"	19.0	45'000
HN5S6 / HN5SV	3"	3"	22.0	45'000
HNVS6 / HNVS7	3"	3"	19.0	45'000
IN5S6	3"	3"	35.0	45'000
INVS6	3"	3"	22.0	45'000
INNT6	3"	3"	25.0	35'000
IN6S6 / INUC6	95 mm	3"	45.0	35'000
INUT6	95 mm	3"	43.0	35'000
LN7C6 / LN7T6	100 mm	100 mm	47.0	35'000
LN7Z6	100 mm	100 mm	49.0	35'000
LNTT6 / LNTZ6	100 mm	100 mm	49.0	35'000
LNTZV	100 mm	100 mm	49.0	35'000
DNYK8 / DNYT8	1 1/2"	1 1/8"	1.2	35'000
ENYS8 / ENYT8	1 1/2"	1 1/8"	1.2	35'000
FNXTW	2"	2"	6.0	50'000
FNXT8 / FNZ8	2"	2"	6.0	50'000
FNXZ9	2"	2"	6.0	50'000
HN4B8 / HN4S8	2 1/2"	2"	14.0	50'000
HNWB8/HNWS8	2 1/2"	3"	14.0	50'000
HN5B8	3"	3"	22.0	45'000
HNVB8	3"	3"	19.0	45'000
IN5B8 / IN5S8	3"	3"	35.0	45'000
INVB8 / INVS8	3"	3"	22.0	45'000
INNTW / INNT8	3"	3"	25.0	40'000
IN6S8	95 mm	3"	45.0	30'000
INUC8	95 mm	3"	43.0	30'000
LN6S8	95 mm	3"	45.0	30'000
LNUCW / LNUC8	95 mm	3"	43.0	30'000
LNUCA	95 mm	3"	43.0	30'000
LN7C8 / LN7T8	100 mm	100 mm	49.0	30'000
LNTT8 / LNTZ8	100 mm	100 mm	49.0	30'000
ENXRA	1 1/2"	1 1/2"	3.8	50'000
HNXTA / HNXZA	2"	2"	8.0	50'000
INVBA / INVSA	3"	3"	22.0	50'000

2.9 ASSEMBLY / DISASSEMBLY**2.9.1 REPLACEMENT OF MECHANICAL SEAL****2.9.1.1 REMOVAL OF PUMP SIDE MECHANICAL SEAL (515)****a) Exposed-spring seal - type "C"**
(Fig. 10)

Remove snap ring (Seeger, 546), then remove spring. Make sure that the shaft is free of burrs and has no sharp edges so that the rubber parts of the seal cannot be damaged as they are removed. Oil the shaft for ease of disassembly. Now the seal rotating parts can be pulled off the shaft by hand.

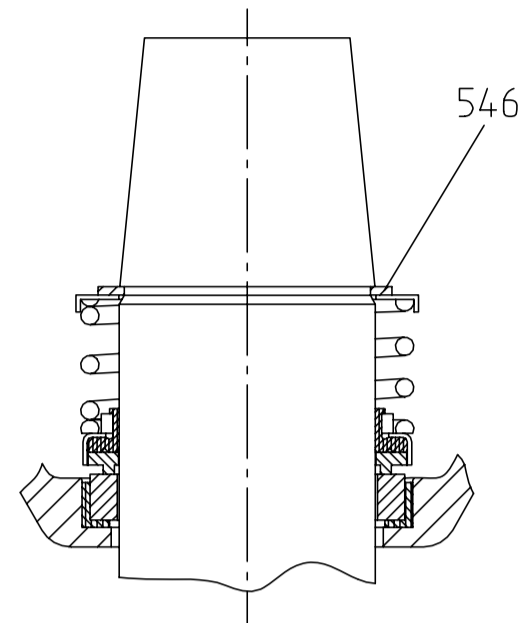

Fig. 10

b) Rubber-bellows seal, internal spring - type "M"
(Fig. 11)

Remove retaining ring "A" from the rubber bellows of the seal by gently prying with two screwdrivers on opposite sides, between the rubber bellows and the retaining ring (Fig. 12).

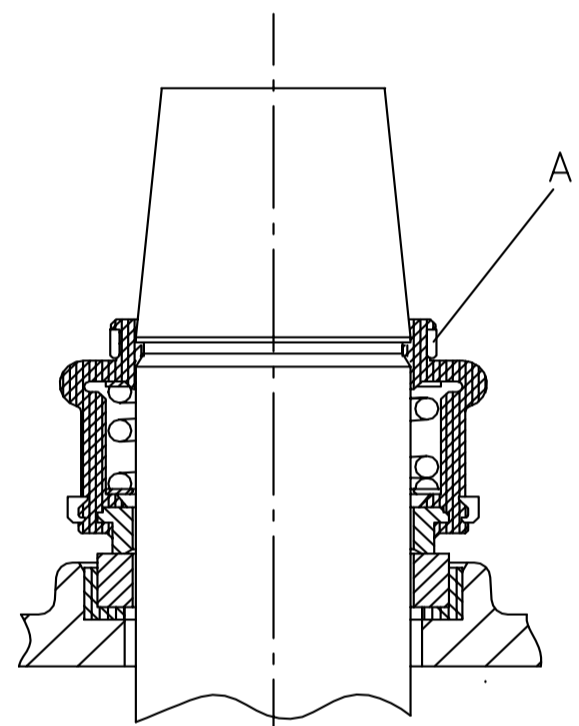

Fig. 11

**WARNING:**

Use only dull-edged screwdrivers since sharp edges could cut the rubber bellows. Do not twist screwdriver, as this can puncture rubber bellows.

Rather, lay some convenient object onto back cover or seal plate, to act as a fulcrum for each screwdriver, and pry ring directly up away from rubber bellows (Fig. 12).

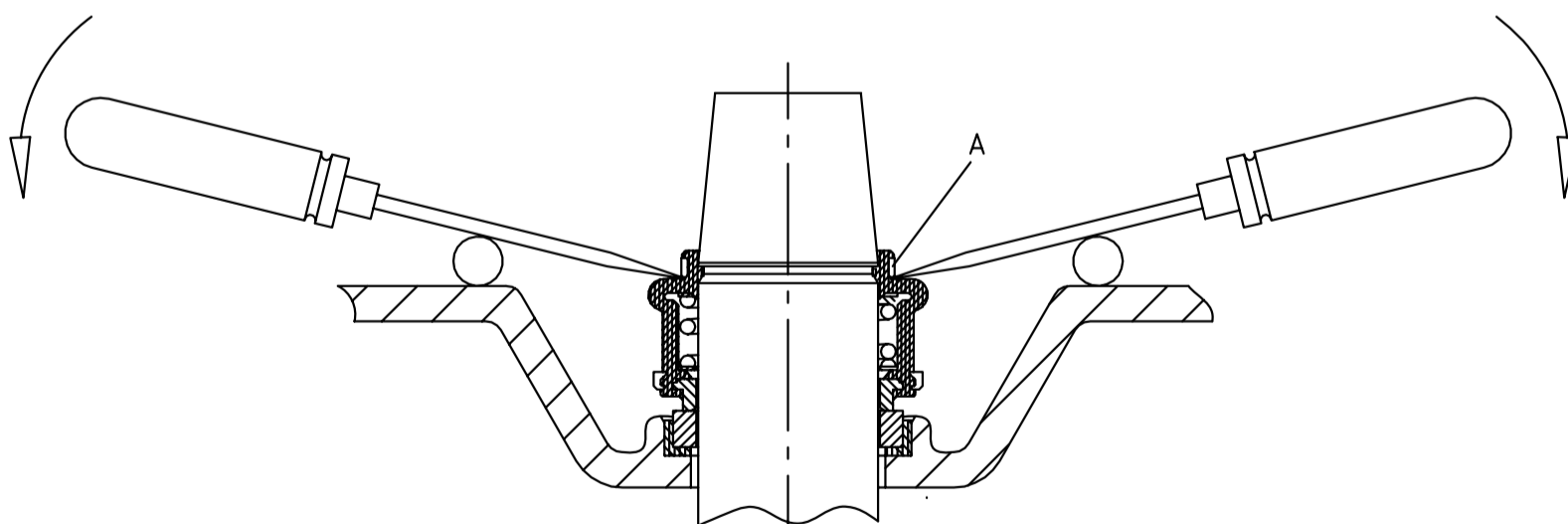

Fig. 12

Make sure that the shaft is free of burrs and has no sharp edges so that the rubber parts of the seal cannot be damaged as they are removed. Oil shaft and bellows for ease of disassembly. Gently insert a screwdriver between the shaft and the rubber bellows.

By lifting and turning the screwdriver around the shaft, the lip of the rubber bellows can be lifted out of the shaft groove. Once the bellows is free of the groove, the entire rotating part of the seal with bellows can be pulled off the shaft. If necessary, use two screwdrivers deep into the seal to pry the seal face loose (Fig. 13).

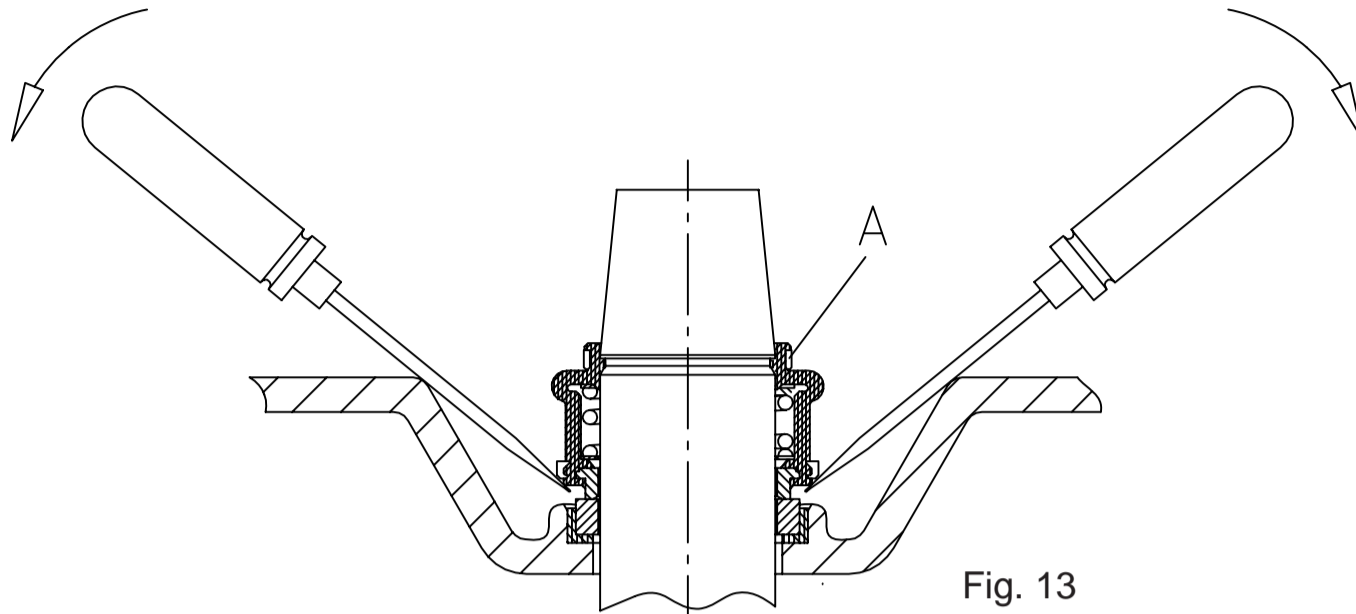

Fig. 13

c) Rubber-bellows seal, external spring - type "G" (Fig. 14)

Remove snap ring (546), if existing. Pull out the removable part (A) by hand.

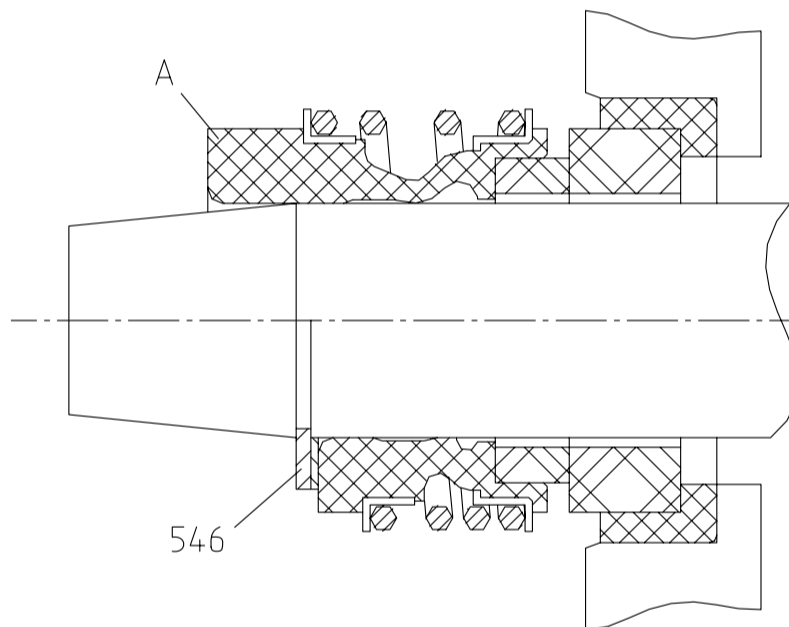

Fig. 14

d) Stainless-steel-shroud seal - type "X" (Fig. 15)

Remove all three small setscrews from outer body of rotating part. Remove snap ring (546). Oil the shaft for ease of disassembly. Now the seal rotating part can be pulled off the shaft by hand.

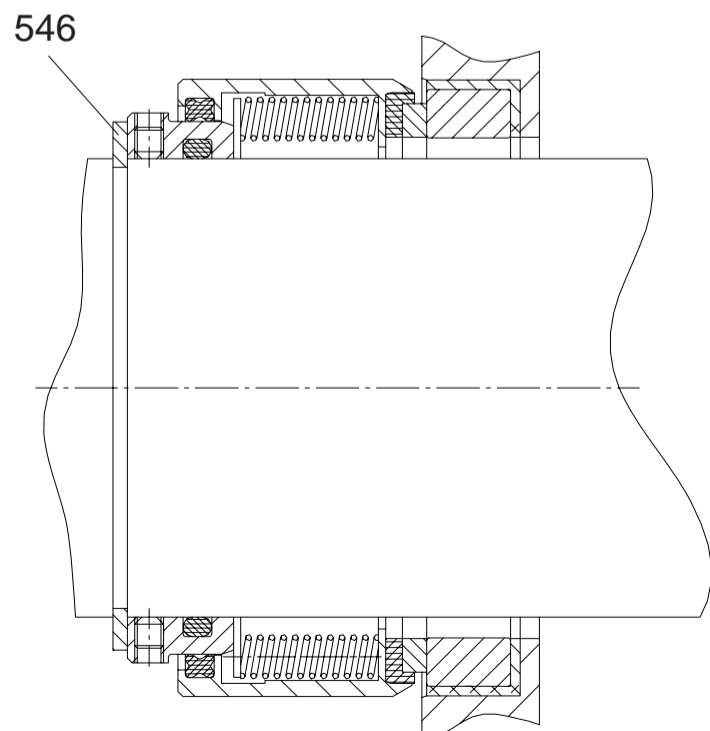

Fig. 15

e) Stationary seat (all types)
(Fig. 16 and 17)

Remove static part of the mechanical seal as follows:

Unfasten nuts (534) and carefully remove back cover or mechanical seal plate (507) from oil chamber casing. Make sure that the static part of the seal (515) does not hit the shaft so that the ring can't be damaged.

Now the static part of the seal can be carefully pushed out of the chamber from the back side.

Some HIDROSTAT seals can be repolished or repaired (Consult nearest service center). When sending a seal for inspection or repair, it is important to thoroughly protect the seal faces to prevent damage during transportation.

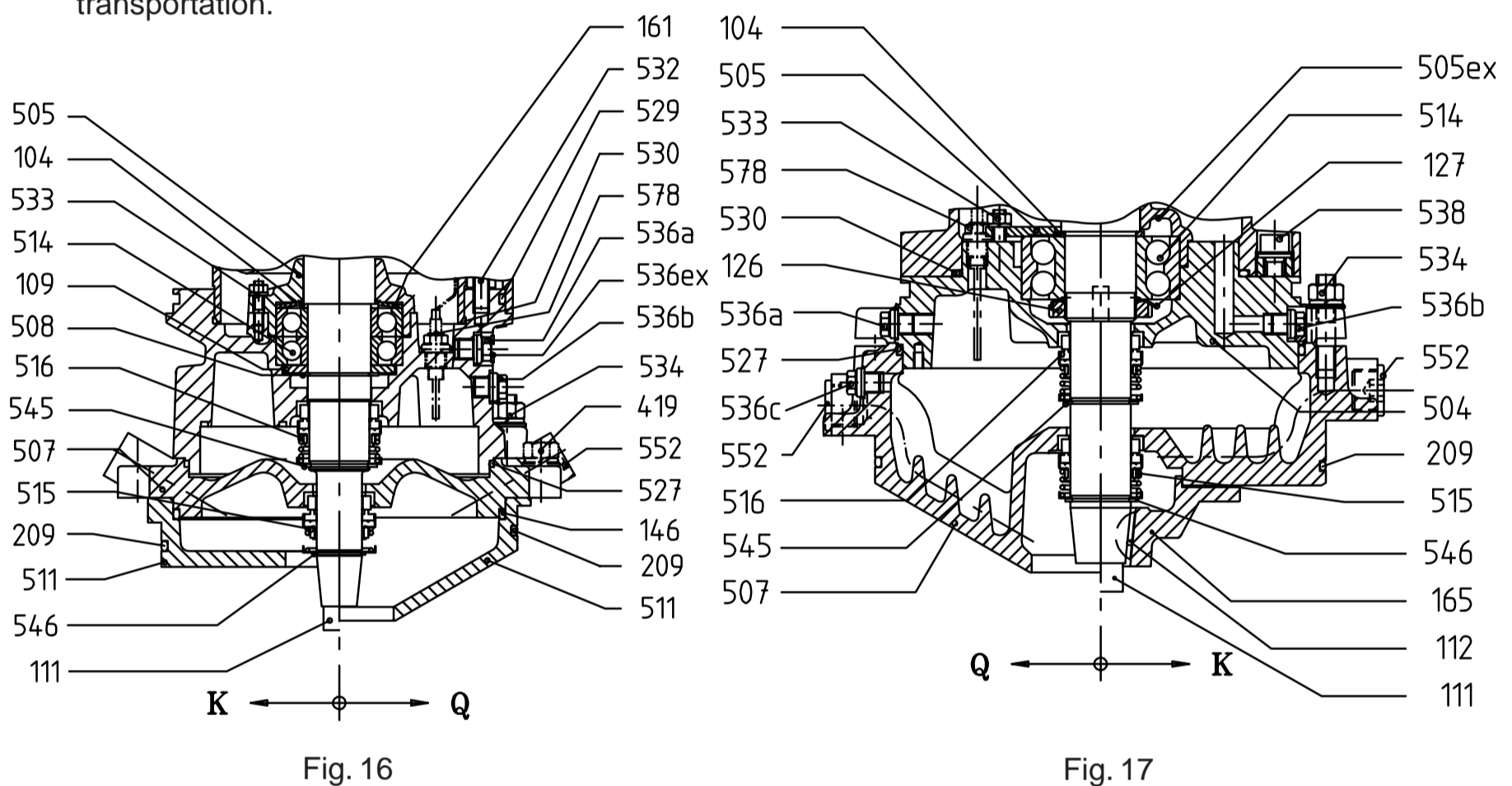

2.9.1.2 MAINTENANCE OF MOTOR SIDE MECHANICAL SEAL (516)

It is **IMPORTANT** to note that removal of this seal should not be attempted in the field. If leakage of this seal has been detected from the motor housing test as described in Section 2.6.3.2, the entire motor should be sent to the nearest authorized HIDROSTAT service center for a complete inspection.

2.9.1.3 ASSEMBLY OF BACK COVER

Cleanliness is of utmost importance for this assembly work! All parts must be washed in solvent before assembly. All machined mating surfaces must be clean and free from burrs. All grooves and seatings for "O"-rings and other static seals must be inspected for nicks or scratches. All threads must be clean especially those in holes for studs. **All "O"-rings MUST be replaced with new ones and they should be lubricated with light oil prior to assembly.**



ATTENTION:

Never use "O"-rings glued from "O"-ring stock. Our experience is that this glue joint will inevitably leak.

Place a new "O"-ring (527) on the oil chamber casing (504). Carefully assemble back cover or mechanical seal plate (507) to the oil chamber casing and fasten with fastening set (534).

2.9.1.4 ASSEMBLY OF PUMP SIDE MECHANICAL SEAL

a) Stationary seat (all types)

Lubricate the rubber circumference of the static mechanical seal part and carefully press all the way into its seat in the back cover or mechanical seal plate (507). The ring must fit tightly in place. Protect the seal face during this operation. Examine gap between shaft and inner diameter of seal face; when face is correctly installed, gap will be uniform all the way around.



ATTENTION:

The seal face is very brittle, and can easily snap unless pressure is uniform during installation. We suggest pushing in with special tool (Fig. 18).

Make sure that the shaft is free of burrs and has no sharp edges, so that the rubber part or the mechanical seal cannot be damaged. File groove edges if necessary.

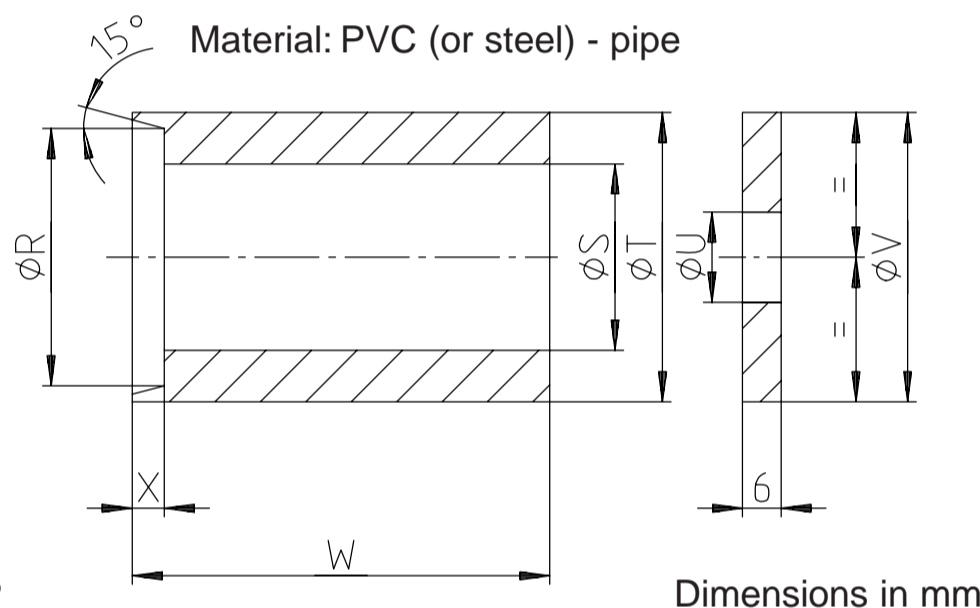

Fig. 18

Dimensions in mm

Seal size	ϕR	ϕS	ϕT	ϕU		ϕV	W	X	Bolt size	
				"Q"	"K"				"Q"	"K"
20	32 +/-1	21 +1/-0	38 +/-1	12	-	40	60	5	M10	-
1 1/8"	40 +/-1	29 +1/-0	45 +/-1	14	12	50	65	5	M12	M10
1 1/2"	50 +/-1	39 +1/-0	55 +/-1	18	14	60	75	5	M16	M12
2"	65 +/-1	51 +1/-0	70 +/-1	22	18	80	95	5	M20	M16
2 1/2"	80 +/-1	64 +1/-0	85 +/-1	29	-	90	150	5	M27	-
3"	92 +/-1	77 +1/-0	100 +/-1	28	29	110	170	5	M33	M27
100	110 +/-1	102 +1/-0	120 +/-1	44	38	130	350	5	M42	M36

b) Exposed-spring seal - type "C"

Remove spring and spring retaining ring of mechanical seal. **Seal surfaces must be absolutely clean!** Place a few drops of light oil on the rotating (carbon) face of the mechanical seal, then lubricate inner bore of rubber part of the seal with oil and put a small amount of oil onto shaft. Install rotating face (with its rubber part) over shaft, and press gently down length of exposed shaft until carbon face touches stationary face. It may help to use a small wood "pusher" or a plastic pipe mandrel only slightly larger than shaft diameter, to push directly on the rubber part of the seal (Fig. 18). Be sure rubber part sits uniformly on shaft, and has *NOT* rolled out from under the metal part of the seal. Put on seal spring, and spring retaining ring.

Install snap ring (Seeger, 546) and turn shaft by hand to check for free running.

c) Rubber-bellows seal, external spring - type "G"

Wet the rotating part of the mechanical seal with soapy water. Push the whole assembly by hand over the shaft as far as possible. On size 20 mm (Fig. 19) final assembly by installing of impeller. On other sizes (Fig. 20) secure with snap ring (546).

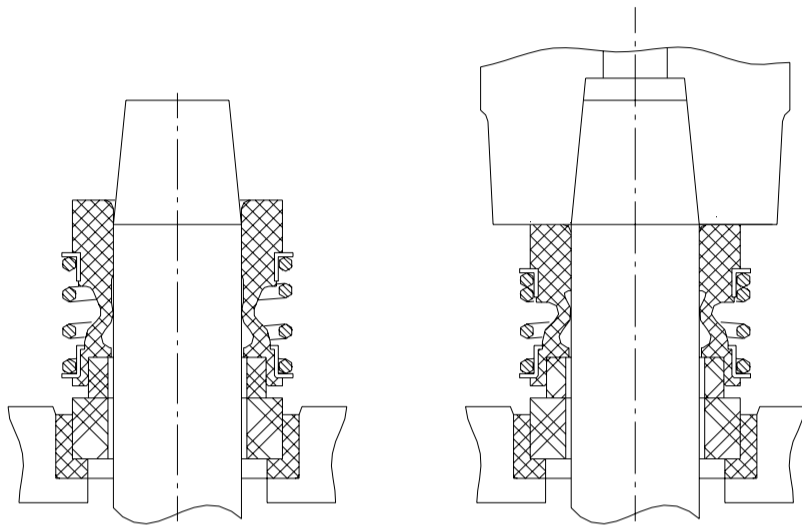

Fig. 19

Fig. 20

d) Rubber-bellows seal, internal spring - type "M"

Lubricate the rotating part of the mechanical seal, position the retaining ring "A" on the rubber bellows (Fig. 21). Push the whole assembly by hand over the shaft as far as possible. Mount the special tool over the shaft tip (Fig. 22), and compress the mechanical seal until the lip of the rubber bellows is engaged in the shaft groove. Remove special tool. Turn the shaft by hand and watch that the retaining ring turns perfectly in line with the rubber bellows and that it is not cocked. Then try to pull the rubber bellows off shaft by hand to make sure that the lip has reliably engaged in the shaft groove.

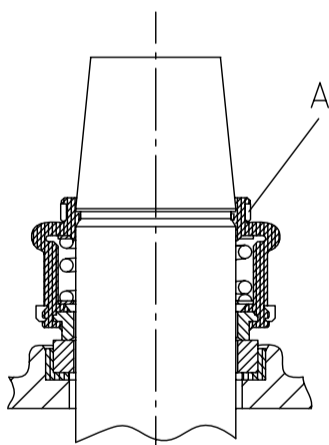

Fig. 21

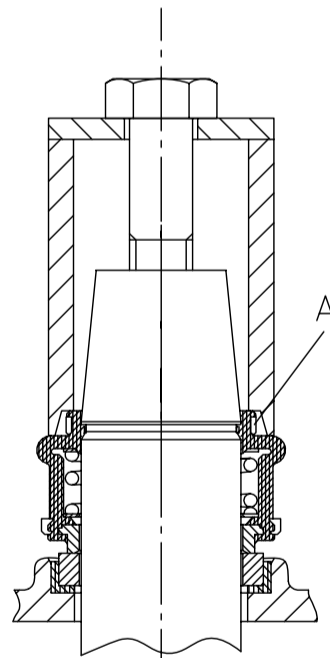

Fig. 22

e) Stainless-steel-shroud seal - type "X"

Lubricate inner rubber O-rings of seal and put a small amount of oil onto shaft. Install entire seal over shaft, and press gently down shaft until rotating face touches stationary face. Now install snapping over shaft, and push until it snaps into its groove. If necessary use the special tool (Fig. 18). Then reinstall the three small setscrews into the seal rotating part, and tighten firmly.

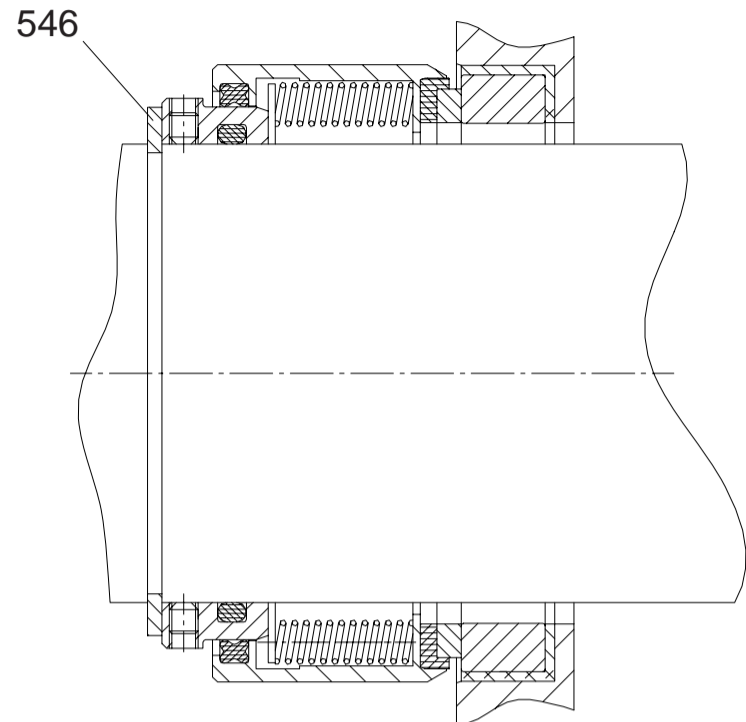

Fig. 23

**2.9.1.5 LEAKAGE TEST FOR PUMP SIDE MECHANICAL SEAL
(All Types)**

Remove screw plug "OIL" (536) and drain the oil from the motor. Connect dry compressed air source such as bicycle tyre pump to the opening. Use a pressure reducing valve and relief valve set to 0.5 bar (7 psi).

**WARNING:**

- Make sure that the pressure never exceeds 1 bar. This could displace the seal.
- Immerse the motor into a test tank full of water and watch for continuously escaping bubbles. This would indicate leakage past the seal or associated "O"-ring.
- **Do not immerse end of cable!**
- Correct failure if leakage has been found. After finishing tightness test remove pressure connection hose and fill with oil according to Section 2.6.3.4.