

**SELF CLEANING SUMP**

Unscheduled maintenance arising from pumps blocking and the need to remove floating and settled solids from the sump should not be a fact of life in waste water handling. Unscheduled maintenance can be avoided by having a pumping system that:-

- a) Uses a pump with impeller geometry that has been specifically designed to handle fibrous material as well as bulky solids and has impeller free passages which increase with pump size
- b) Virtually empties the sump every pumping cycle
- c) Skims the surface of all floating materials, particularly oils and fats every pumping cycle.
- d) Has a sump with a small floor area, so all settled solids are swept to the pump suction by the residual sump velocity

By installing Hidrostal's self-cleaning network pumping station incorporating screw centrifugal impeller technology and Hidrostal's self cleaning sump unscheduled maintenance can be eradicated.

**WHY DOES HIDROSTAL'S SCREW CENTRIFUGAL PUMP HANDLE RAGS AND SOLIDS SO EFFECTIVELY?****Self Cleaning Impeller**

The screw centrifugal impeller incorporates special geometry that ensures any rags and fibre which contact the inlet edge of the blade are automatically swept to the centre of the impeller where they are deposited into the flow and pass freely through the pump. See diagram below for a detailed explanation.



1



2



3

1. Flow parallel to leading edge of blade
2. Rags/Fibre impinges on impeller leading edge
3. Flow pushes rags along blade towards the centre
4. Rags moved off the blade into impeller channel and pass freely through the pump



4

Thirty years of worldwide field experience confirms that the use of Hidrostal's Self Cleaning Screw Centrifugal pump stops the build-up of rags and fibre at the impeller inlet, thus preventing pump blockages – a major operational cost.

**Passes large solids**

The impeller also has a large free passage that progressively increases with the pump size so ensures that solid objects or bundles of rags or matted materials that arrive at the pump inlet will pass through the pump without causing blockages.

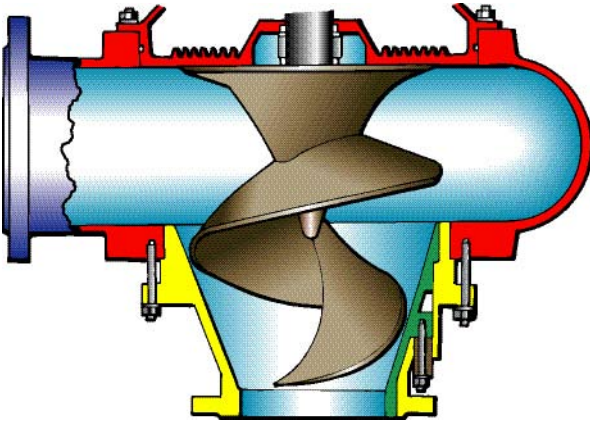

Branch Size	Typical Free Passage mm Ø
80	70 & 60
100	100 & 76
125	100 & 95
150	125 & 115
200	150 & 100
250	160 & 120
300	220 & 150
400	290 & 180
500	230
700	300

**SUMP CLEANING**

Keeping wet wells [sumps] free of floating and settled solids has always been a major issue for operators of wastewater and sewage pump stations.

Typical problem:



Accumulation of material floating on surface of sump

Maintenance of wet wells frequently involves man entry into a confined space which is not only anti-social but is potentially dangerous and an expensive operation. In addition there is the cost of deploying a vacuum tanker and its attendant crew.

**An expensive operation which can be eliminated by use of a Hidrostal Self Cleaning Sump.**

The principle for the Self Cleaning Sump has been derived from Hidrostal's well-known Prerostal™ system. Prerostal™ systems have been in use for more than thirty years on sewage and wastewater pump stations where there is a requirement to match outflow to inflow. During many years of operation it has been observed that the Prerostal system automatically removes all floating material every pumping cycle as well as fulfilling its primary intent of matching outflow to inflow.

The Self Cleaning Sump is a simplified version of the Prerostal™ system where the primary intent is to clean the sump of floating and settled solids each pumping cycle so as to eliminate costly sump maintenance [for further details of the prerostal™ system see Section 10.1]

**THE HIDROSTAL SELF CLEANING SUMP**

In network and district pump stations the primary desire of the operations staff is to reliably pump unscreened raw sewage without the need for call outs to unblock pumps and the costly periodic process of removing floating and settled solids by the use of vacuum tankers. The Hidrostal Self Cleaning sump has been designed to fulfil both of these wishes.

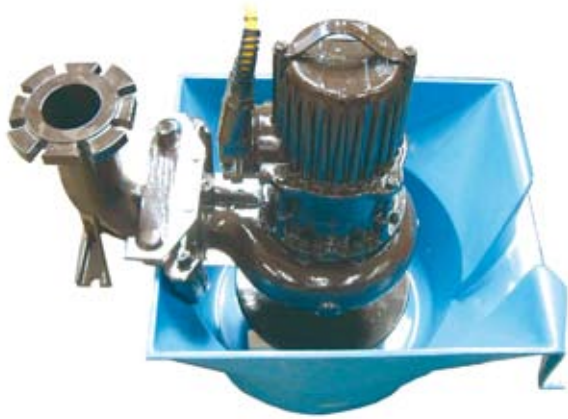

Standard guide-rail mounted hidrostal submersible pump complete with GRP Basin and Bellmouth

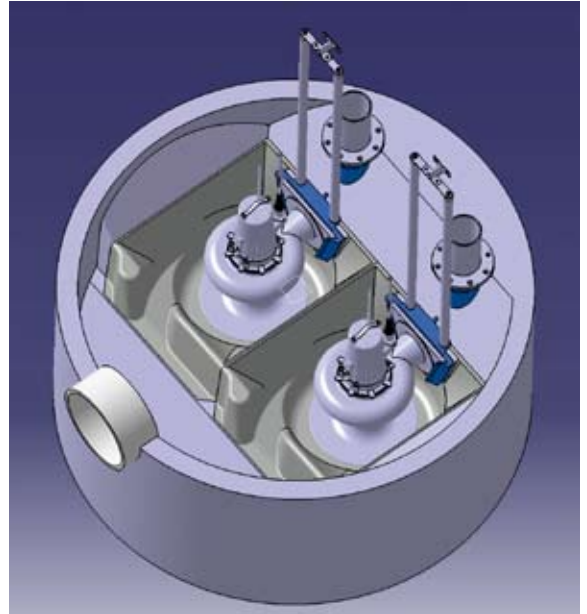

Self cleaning sump – top view

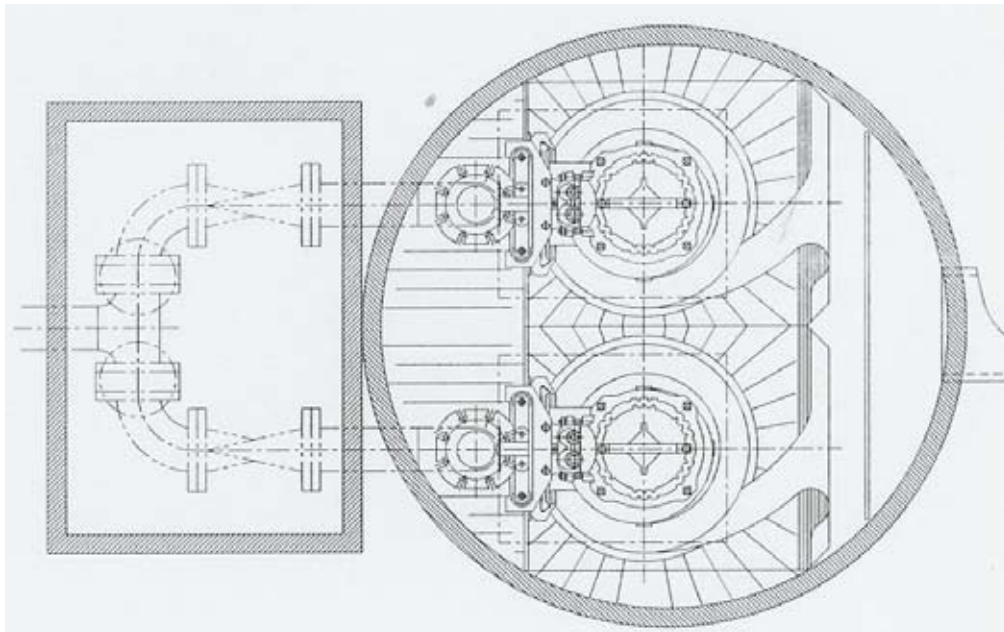
**EXAMPLE**

A self-cleaning sump with two 100 mm Hidrostal pumps installed in a 1800 mm Ø concrete ring with external valve chamber

Self Cleaning Sumps are available for Hidrostal pump models B03M through to E08M, covering flows from 10 l/s to 120 l/s. For larger flows the classical Prerostal system can be used.

**With this system incorporated into a submersible pump station there is, for the first time, a real prospect of eliminating costly unscheduled maintenance.**

