

Submersible and Immersible Pumps



A range of quality pumps featuring the unique Hidrostral Screw Centrifugal Impeller.

Models are available for fully, partially submerged or dry installation and designed for:

- SOLIDS HANDLING
- VISCOUS PUMPING
- DELICATE HANDLING



Hidrostral

SOUTHERN AFRICA (PTY)LTD

HIDROSTAL PUMPS ...

This brochure provides an introduction to the Hidrostral range of submersible and immersible pumps.

Of advanced design and superior quality, the pumps, available in a wide range of sizes, are in use throughout many industries world-wide in an extensive range of applications. Based on the unique Screw Centrifugal Impeller, developed and patented by Hidrostral, the pumps also incorporate features found only in Hidrostral products. Hidrostral engineers and their approved agents and distributors, can provide detailed information on selection and installation.

DESIGN PHILOSOPHY

Hidrostral's philosophy is to blend innovative ideas with well tested pump designs, to produce value for money products to minimise the life-time cost of ownership.

The objective of the design process is to:

- Make available a range of build options to suit a wide variety of applications.
- To maintain interchangeability across all generations of pumps. This flexibility permits sub-assemblies like hydraulic ends, bearing frames and submersible/ immersible motors to be exchanged at any time to allow the users to take advantage of the latest developments in pump technology.
- The possibility to upgrade the specification at any time for changing operating conditions.

MINIMUM LIFETIME COSTS

It is acknowledged by leading Water Companies that the initial purchase price of a typical waste water/sewage pump, represents only about 5% of the total costs of purchasing, operating and maintaining the product over a 15 year period. Hidrostral acknowledge this fact by concentrating on manufacturing products which minimise the running and maintenance costs.

Hidrostral submersible / immersible pumps are easily maintained, and can be fully dismantled, repaired and assembled without the use of special tools. Routine adjustments such as maintaining optimum running clearances is simple and keeps operating and running costs to a minimum.

A combination of high pump efficiency, reduction in maintenance time and a low level of replacement parts provides to Hidrostral users, unmatched value for money.

THE SCREW CENTRIFUGAL IMPELLER

All Hidrostral pumps incorporate the company's Screw Centrifugal Impeller.

Extremely versatile in its applications, the impeller provides efficient handling of a range of liquids, often highly abrasive or corrosive in nature. It is ideal for:

- Solids Handling
- Pumping Viscous Sludges
- Handling Delicate or Low Shear Products

Unique to all Hidrostral pumps is the ability to handle the above in combination.

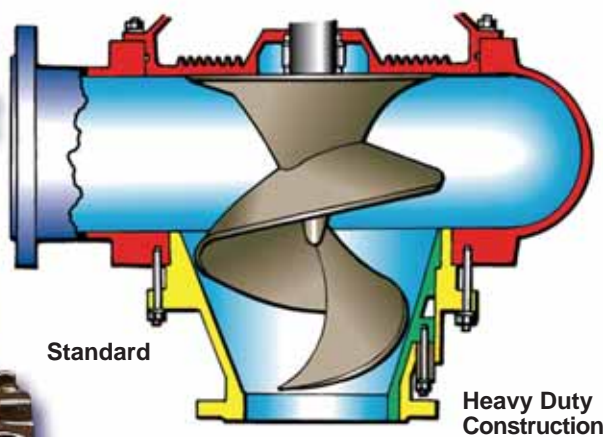

Many applications too arduous for other types of centrifugal pumps can usually be handled by the Hidrostral screw centrifugal impeller. The impeller comprises a single spiral vane, having large open passages, which makes a long slow turn from the axial inlet to the radial outlet. The design provides optimum hydraulic performance giving:

- High efficiencies
- Steep and stable hydraulic curve
- Non-overloading power curve
- Low NPSH
- Non-clog pumping

Typical applications:

- Industrial effluents
- Raw unscreened sewage
- Viscous sludges
- Return activated sludges
- Drainage/Stormwater
- Process Waste

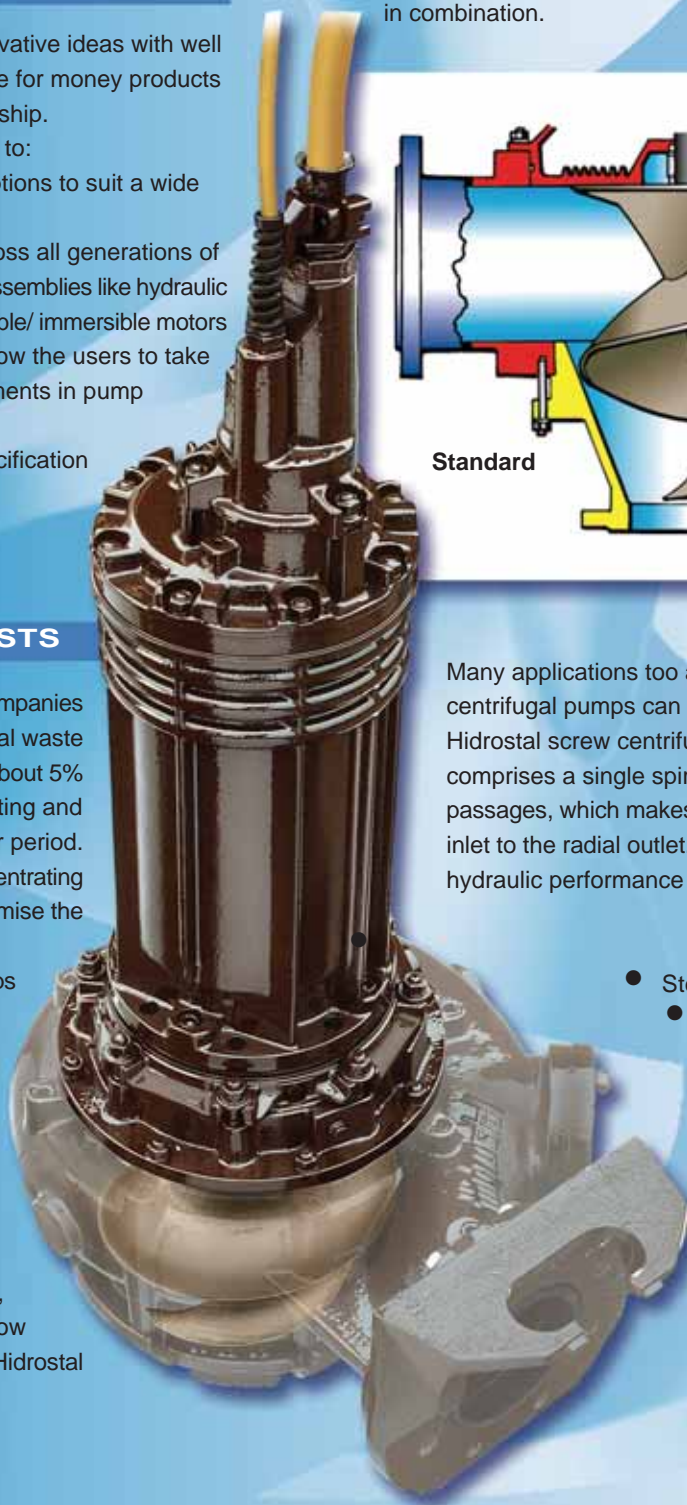

...UNIQUE AND DEPENDABLE

SUBMERSIBLES

Pumps are heavy-duty construction, designed to operate at depths of 20 metres with special versions available for depths to 200 metres.

GUIDE RAIL MOUNTED

For permanent installation and ease of maintenance, a guide rail mounting arrangement is available. Twin guide rails ensure the pump is guided to the discharge elbow and correctly locates in position to give a leak-free connection.

FREE-STANDING OR PORTABLE UNITS

For applications where a permanent guide rail system is inappropriate, or a temporary arrangement is required, all Hidrostal submersible (and immersible) pumps can be used as free-standing

AXIAL FLOW - Tube mounted

Hidrostal 'A' type pumps are designed for low head applications up to 10m and flows from 30 to 1,100l/s. The axial pump range is based around Hidrostal's standard range of submersible motors having the same benefits as previously described. The difference is that the volute on the low pressure versions is replaced with a casing having an axial discharge enabling the pumps to be installed in a tube or concrete chamber.



IMMERSIBLES

Hidrostal immersible pumps are a versatile, innovative development of the established submersible range. Capable of continuous operation in a dry installation, the immersibles may be operated, with equal efficiency, when fully or partially submerged.

The pumps are particularly suited for dry pit applications where the combination of the Screw Centrifugal Impeller and immersible motor can be considered the state-of-the-art technology.

Leakage of the pumped product is eliminated by tandem seals running in an oil bath, avoiding a situation commonly experienced with soft-packed glands. Hidrostal immersible waste water / sewage pump stations have frequently been mistaken for clean water stations, due to the lack of odour and the cleanliness of the buildings. Immersible pumps are particularly suitable for installation where quiet running, clean surroundings, reliable and long trouble-free operation is required. The pumps may be installed vertically or horizontally.



ADVANTAGES OF DRY PIT INSTALLATION

- Quiet running
- Cool exterior
- No leakage of product
- Compact, simple installation
- No exposed rotating shafts or couplings
- Pump easily opened for inspection
- Vertical or horizontal installation
- Clean odour-free waste water pump stations

ADVANTAGES OF WET PIT INSTALLATION

- Pumps can be installed in the same manner as submersible pumps
- Liquid level can be drawn down to pump casing without risk of overheating the motor
- Shallower sumps compared with conventional submersible pump installations
- Full motor rating maintained when pumping sludge



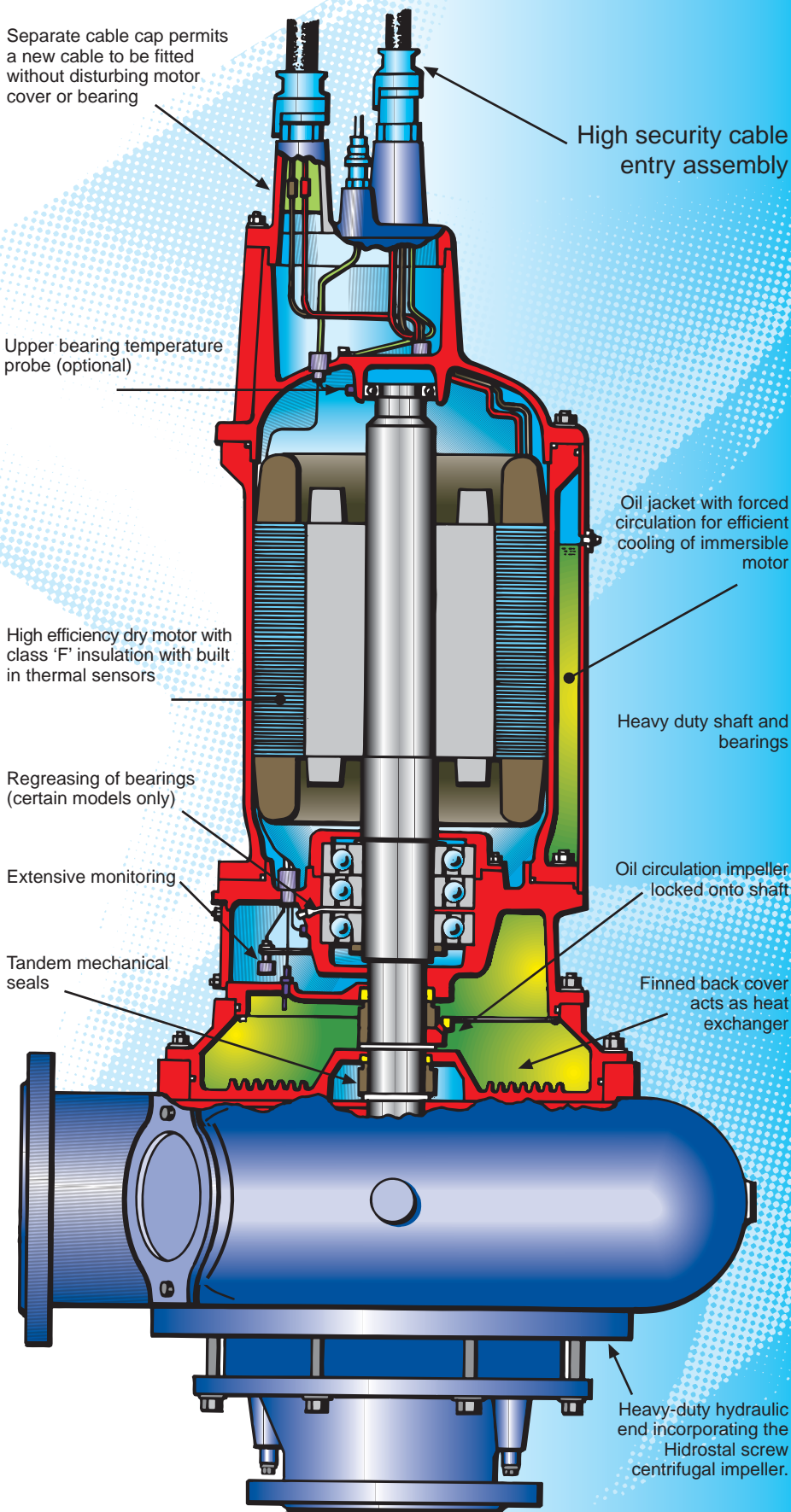

MOTOR

Cooling

All immersible motors are efficiently cooled by oil, contained within a jacket, circulated around the motor, by an impeller locked to the motor shaft.

The oil transfers the heat to the pumped liquid, through a finned back cover between the pump and the motor. The Hidrostal cooling method has advantages over other systems which circulate the pumped liquid through internal cooling channels which often become coated with sludge and slime, reducing the heat transfer and effectively derating the motor.

Tandem Mechanical Seals

Both seals run in an oil bath which lubricates the pump side seal faces in the event of dry running. The pump side seal has faces of tungsten carbide run-ning against silicon carbide, effective for abrasive applications.

For heavy-duty applications the pumpside seal springs are totally enclosed in a rubber boot or metal body depending on application. Motor side seals are of the open spring type with carbon/ceramic faces.

Regreasing of Bearings

The lower bearing carries the axial thrust, the weight of the rotating unit and substantial radial loads. To fulfil its L10 design life, periodic regreasing is necessary on certain models. This is easily done by removing a water-tight cover which exposes a greasing nipple. The upper bearing carries a lighter load and does not require regreasing between major overhauls.

Inverters and Soft Starts

All Hidrostal motors can operate with inverters and soft starts, provided quality electrical elements of approved specification are used.

Explosion Proof Motors

All 50hz motors are approved by PTB for explosion proof applications to IEC EExd IIB, T3 or T4 and by Factory Mutual for 60hz. FM: EXP/II/1/CD.

Two Speed Motors

Dual wound, two speed, submersible and immersible motors are available to suit individual applications.

Head Office :
91 Kya Sand Road, Kya Sand 1685, Republic of South Africa
PO Box 122, Kya Sand 2163, Republic of South Africa
Tel: (011) 704 5333 Fax: (011) 704 5666 E-mail : hstal@mweb.co.za Website: www.hidrostal.com

Eastern Cape:
30 Drury Street, North End, Port Elizabeth 6056, Republic of South Africa
PO Box 20172, Humewood, Port Elizabeth 6013, Republic of South Africa
Tel: (041) 487 3706 Fax: (041) 487 3707

Kwa-Zulu Natal :
Unit 3, 27 Beechgate Crescent, Southgate Industrial Park, Amanzimtoti 4126, Republic of South Africa
PO Box 159 Warner Beach 4140, Republic of South Africa
Tel: (031) 914 1007/9 Fax: (031) 914 1012

Hidrostal
SOUTHERN AFRICA (PTY)LTD